



USER MANUAL

PM Series

Model: PM3320-100KVA, PM3320-60KVA,
Cabinet: PM3320-RM, PM3320-SA, PM3315-RM, PM3310-RM

UDD-SD-127

USER MANUAL

USER MANUAL

PM Series

Model: PM3320-100KVA, PM3320-60KVA,
Cabinet: PM3320-RM, PM3320-SA, PM3315-RM, PM3310-RM

All rights reserved.

The information in this document is subject to change without notice.

Publish statement

Thank you for purchasing this series UPS.

This series UPS is an intelligent, three phase in Three phase out, high frequency online UPS designed by our R&D team who is with years of designing experiences on UPS. With excellent electrical performance, perfect intelligent monitoring and network functions, smart appearance, complying with EMC and safety standards, The UPS meets the world's advanced level.

Read this manual carefully before installation

This manual provides technical support to the operator of the equipment.

About The Manual

This manual is prepared for the users of Model: PM3320-100KVA, PM3320-60KVA,
Cabinet: PM3320-RM, PM3320-SA, PM3315-RM, PM3310-RM

Companion Manuals

For further information about this device and its options, please visit www.makelsan.com.tr

Updates

Please visit www.makelsan.com.tr for updates. Always use the latest manuals.

CONTENTS

1 SAFETY	4
1.1 Safety Notes	4
1.2 Symbols Used in This Guide	4
2 MAIN FEATURES	5
2.1 Summarization	5
2.2 Functions and Features	5
3 INSTALLATION.....	7
3.1 Unpack Checking	7
3.2 Cabinet Outlook.....	7
3.3 UPS Module Appearance	13
3.4 UPS Module LCD Control Panel	14
3.5 Installation Notes	14
3.6 External Protective Devices	16
3.7 Power Cables.....	16
3.8 Power Cable Connect.....	17
3.9 Battery Connection.....	21
3.10 Online UPS Modules Replacement.....	22
3.11 UPS Multi-Module Installation	23
3.11.1 Cabinet Installation	23
3.11.2 Parallel Cable Installation.....	24
3.11.3 Parallel Board Jumper Modification.....	25
3.11.4 Requirement for the Parallel System.....	26
4 OPERATION	27
4.1 Operation Modes	27
4.2 Turn on/off UPS.....	27
4.2.1 Restart Procedure	27
4.2.2 Test Procedure.....	29
4.2.3 Black (Cold) Start Procedure	29
4.2.4 Maintenance Bypass.....	30
4.2.5 Shut Down Procedure	31
4.2.6 Startup Procedure for Parallel System	31
4.3 The Display	32
4.3.1 System LCD Display	32

- 4.3.2 UPS Module LCD Display 40
- 4.3.3 Monitoring Module Control Panel 46
- 4.4 Display Messages/Troubleshooting..... 48
- 4.5 Options..... 54
- Appendix 1 Specifications 57**
- Appendix 2 UPS message table 58**
- Appendix 3 Problems and Solution 64**
- Appendix 4 RS232 communication port definition..... 66**
- 5 GUARANTEE..... 68
 - 5.1 Terms of Guarantee 68
 - 5.2 Cases Not Covered by the Guarantee 69
- 6 CONTACT INFORMATION..... 73

1 SAFETY

Important safety instructions – Save these instructions

There exists dangerous voltage and high temperature inside the UPS. During the installation, operation and maintenance, please abide the local safety instructions and relative laws, otherwise it will result in personnel injury or equipment damage. Safety instructions in this manual act as a supplementary for the local safety instructions. Our company will not assume the liability that caused by disobeying safety instructions.

1.1 Safety Notes

Even no connection with utility power, 220/230/240VAC voltage may still exist at UPS outlet !

For the sake of human being safety, please well earth the UPS before starting it .

Don't open or damage battery, for the liquid spilled from the battery is strongly poisonous and do harmful to body !

Please avoid short circuit between anode and cathode of battery, otherwise, it will cause spark or fire !

Don't disassemble the UPS cover, or there may be an electric shock !

Check if there exists high voltage before touching the battery

Working environment and storage way will affect the lifetime and reliability of the UPS. Avoid the UPS from working under following environment for long time

- Area where the humidity and temperature is out of the specified range(temperature 0 to 40°C, relative humidity 5%-95%)
- Direct sunlight or location nearby heat
- Vibration Area with possibility to get the UPS crashed.
- Area with erosive gas, flammable gas, excessive dust, etc

Keep ventilations in good conditions otherwise the components inside the UPS will be over-heated which may affect the life of the UPS.

1.2 Symbols Used in This Guide



WARNING!

Risk of electric shock



CAUTION!

Read this information to avoid equipment damage

2 MAIN FEATURES

2.1 Summarization

Our UPS is a kind of three-in- three -out high frequency online UPS, it provides three specifications: The 60K,100K and 200K. The products are modularized and adopt the N+X redundancy. It can flexibly increase the number of the UPS modules according to the load capacity which is convenient for flexible allocation and gradually investment.

The UPS can solve most of the power supply problems, such as blackout, over-voltage, under-voltage, voltage sudden drop, oscillating of decreasing extent, high voltage pulse, voltage fluctuation, surge, inrush current, harmonic distortion (THD), noise interference, frequency fluctuation, etc..

This UPS can be applied to different applications from computer device, automatic equipment, communication system to industry equipment.

2.2 Functions and Features

Digital control

- 19-inch standard cabinet

1.4-meter and 2-meter high cabinets are provided according to the user's requirement.

- Modularized design
- High power-density design

The height of the single module is 3U, a standard 1.4m cabinet can hold 5 pieces modules and a standard 2M cabinet for 10 models can reach maximum as below:

60KVA cabinet: 5 x 10K or 4 x 15K or 3 x20K modules

100KVA cabinet: 5 x 10K/15K/20K modules

200KVA cabinet: 10 x 10K/15K/20K modules

- N+X parallel redundancy

This series UPS adopts N+X parallel redundancy design, user can set different redundancy according to the importance of the load. While the redundancy modules are set more than two, the availability of UPS system will achieve 99.999%, which may satisfy the required reliability of the critical load connected. Through LCD display setting, you may configure the required quantity of the redundancy unit. When the load connected is over the number of the

PM SERIES

redundancy, the UPS will alert right away. The design of the MTBF(Meantime before Failure) is up to 250,000 hours.

This series can set the number of redundancy modules. When the load exceeds the redundancy setting, the UPS can still work normally and simultaneously send out corresponding warning as long as the load doesn't exceed the total capacity of modules.

- Parallel Redundant control system
- Optimizing distributed convergence for the cabinet
- Separated Bypass
- Common Battery
- Configurable Battery Voltage (32-40pcs)
- Automatic charge current adjustment according to battery capacity connected.
- 3-Stage Intelligent charging
- Touch-screen Super-large LCD display(Optional)
- Each module with individual LCD display
- Remote Monitoring via SNMP
- Optional Accessories available such as Isolation transformer, Distribution Panel, SNMP Card, Relay Contact Board, etc..
- Equip with Maintenance Bypass Switch for easy maintenance purpose.
- Superior MTTR(Meantime to repair) & Short shutdown time in maintenance
- Centralized monitoring module is also available
- EPO function

3 INSTALLATION

3.1 Unpack Checking

Don't lean the UPS when moving it out from the packaging

Check the appearance to see if the UPS is damaged or not during the transportation, do not switch on the UPS if any damage found. Please contact the dealer right away.

Check the accessories according to the packing list and contact the dealer in case of missing parts.

3.2 Cabinet Outlook

1.4M 19" Rack Cabinet (60/100KVA)

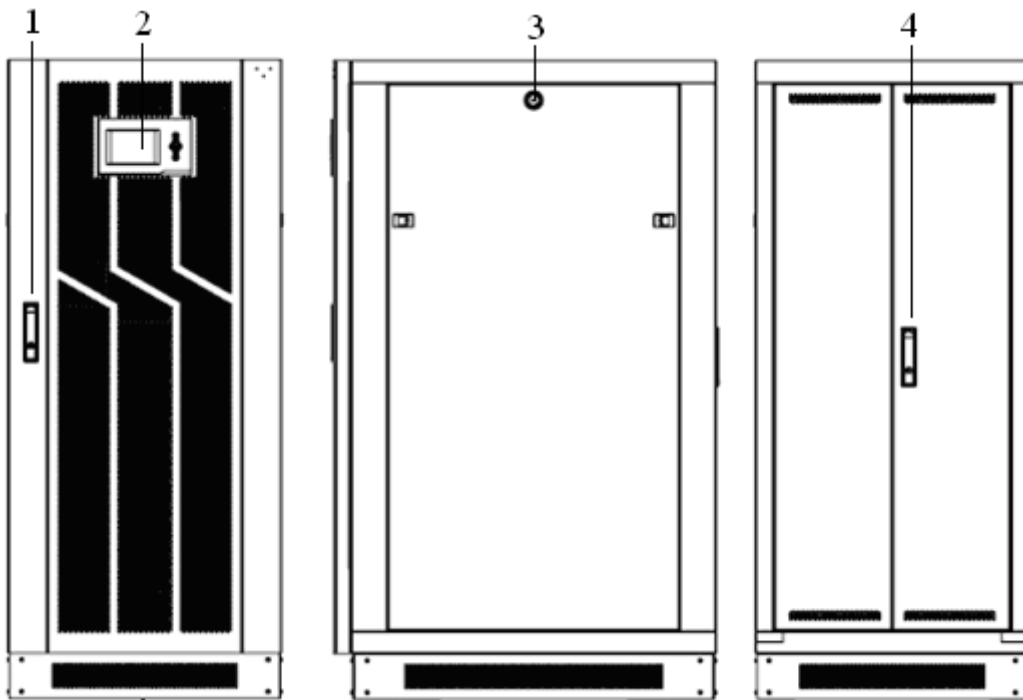

Front View

Side View

Rear View

1. Front lock
2. LCD Display
3. Side Lock
4. Rear Lock

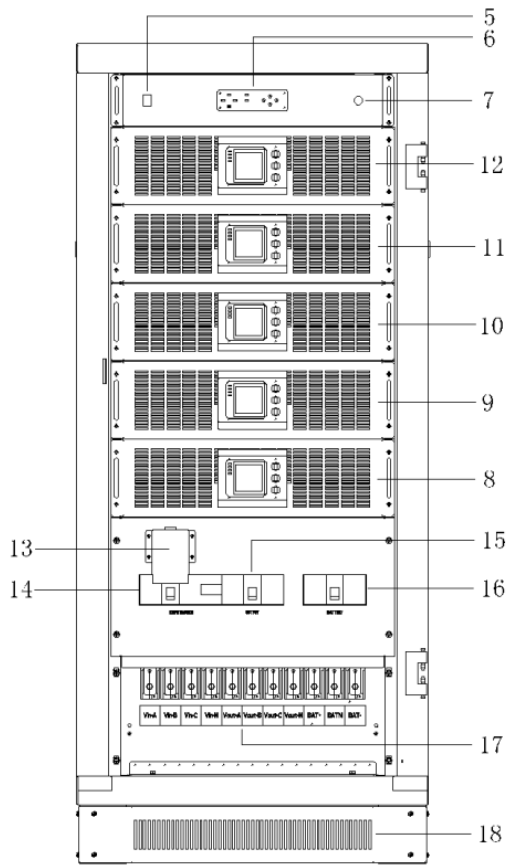

Front View(internal)

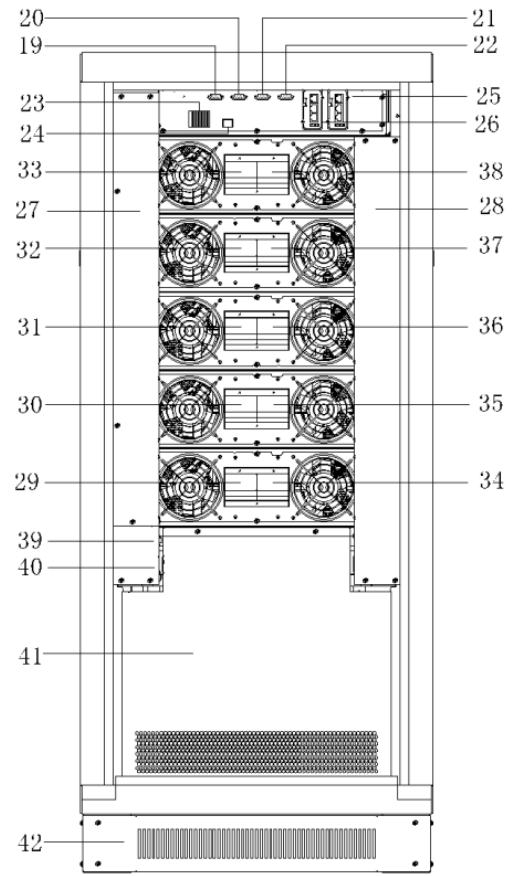

100KVA Rear View (terminal block without cover)

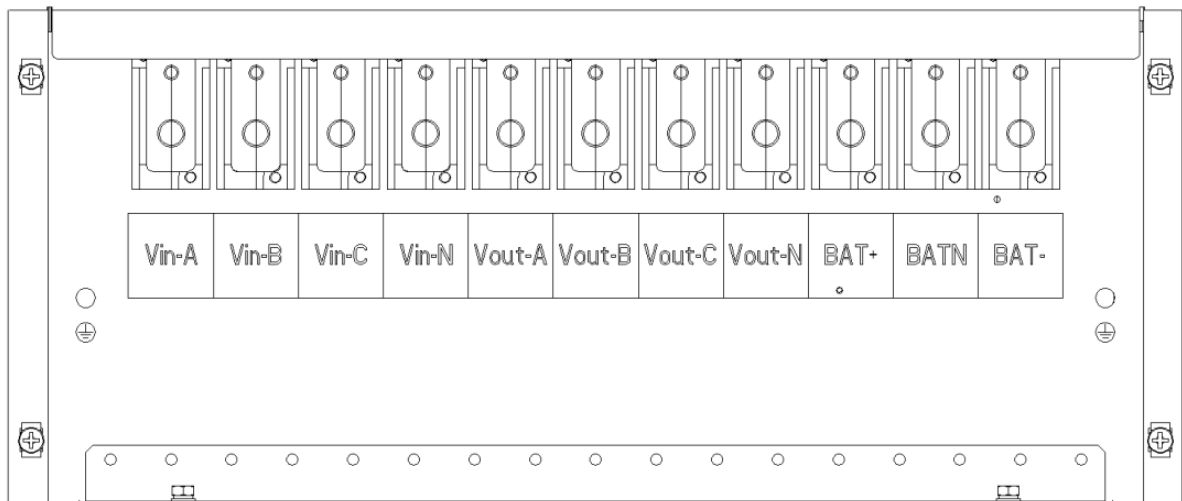

100KVA Terminal Block of the cabinet (terminal block without cover)

5. Main Switch of Central Monitor Unit	25. SNMP port
6. LED display of Central Monitor Unit	26. Intelligent Network Port
7. EPO switch	27. PDU input
8. UPS Module 1	28. PDU Output
9. UPS Module 2	29. Main Switch for UPS Module 1
10. UPS Module 3	30. Main Switch for UPS Module 2
11. UPS Module 4	31. Main Switch for UPS Module 3
12. UPS Module 5	32. Main Switch for UPS Module 4
13. Maintenance switch cover	33. Main Switch for UPS Module 5
14. Maintenance switch	34. bypass switch for power module 1
15. O/P Switch	35. bypass switch for power module 2
16. Battery switch	36. bypass switch for power module 3
17. Terminal block for Input, output & battery	37. bypass switch for power module 4
18. bottom cover for front door	38. bypass switch for power module 5
19. RS485 port	39. Parallel port
20. RS485 port	40. SCI Update port
21. RS232 port	41. Cover for terminal block
22. OPTION port	42. bottom cover for rear door
23. Dry Contact Port	
24. LCD Connecting Port	

2M 19" Rack Cabinet

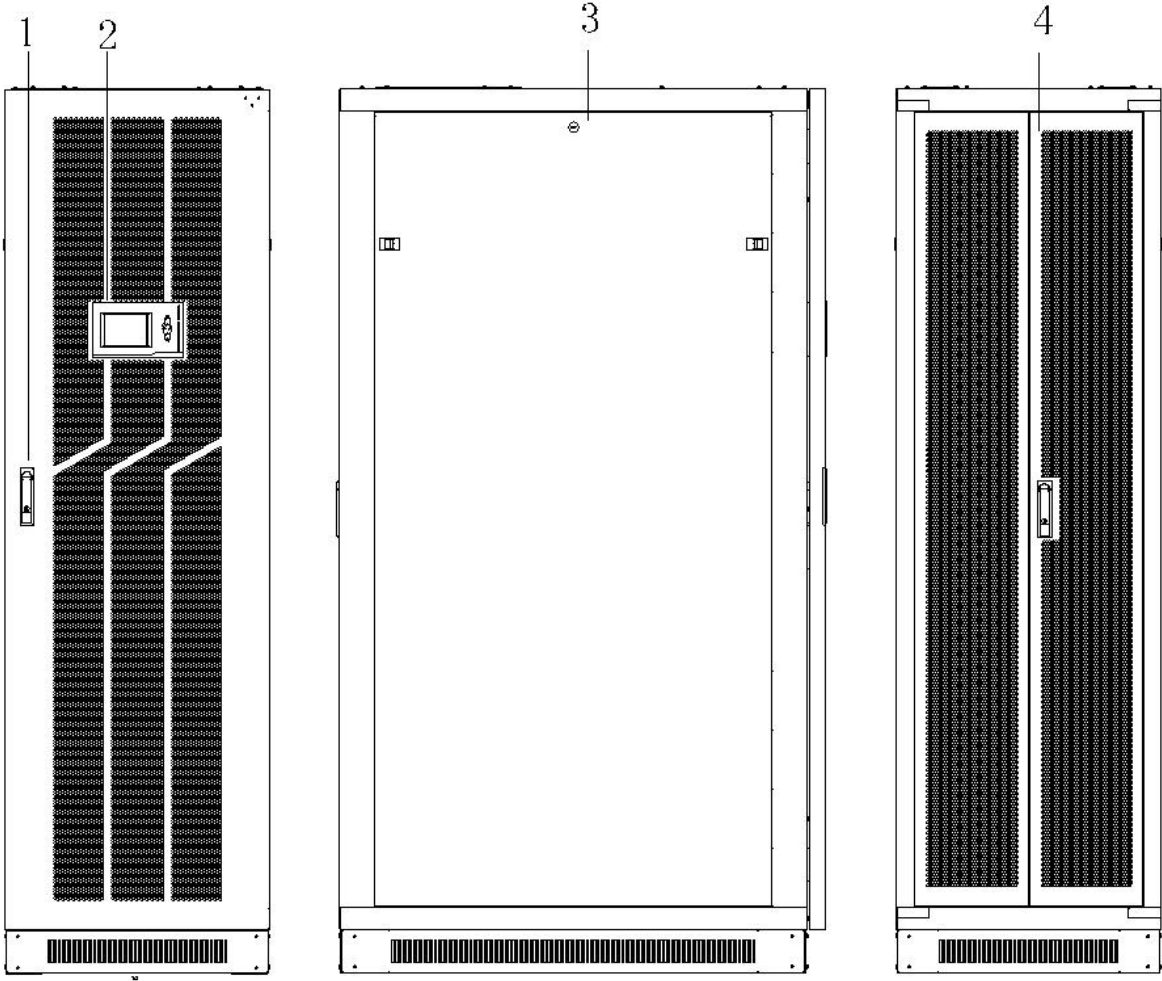

Front View

Side View

Rear View

- 1. Front lock
- 2. LCD Display
- 3. Side Lock
- 4. Rear Lock

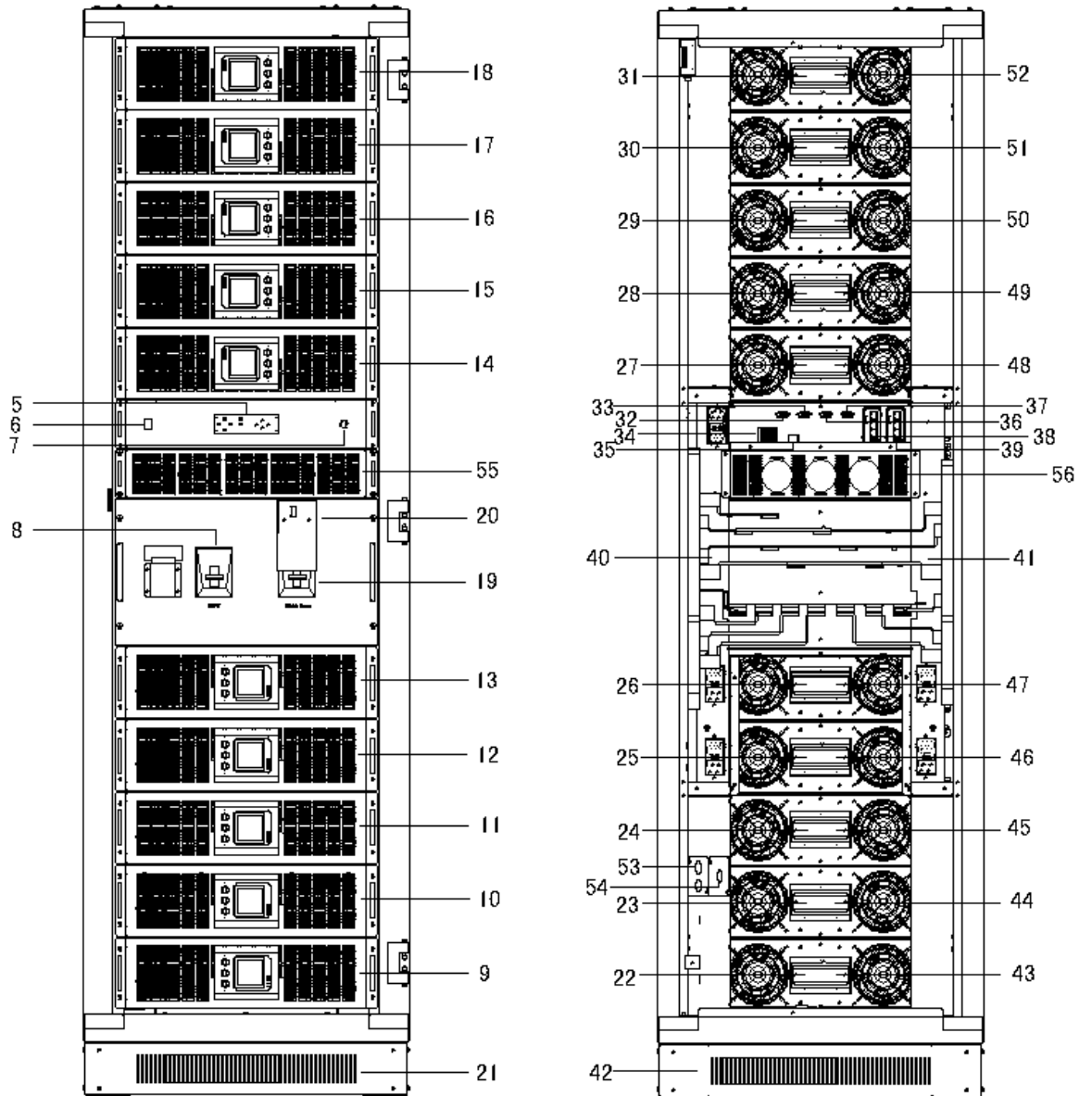

200KVA Front View(internal) 200KVA Rear View (terminal block without cover)

<ul style="list-style-type: none"> 5. Main Switch of Central Monitor Unit 6. LED display of Central Monitor Unit 7. EPO switch 8. O/P Switch 9. UPS Module 1 10. UPS Module 2 11. UPS Module 3 12. UPS Module 4 13. UPS Module 5 14. UPS Module 6 15. UPS Module 7 16. UPS Module 8 17. UPS Module 9 18. UPS Module 10 19. Maintenance Switch 20. Maintenance switch & its cover 21. Bottom cover for front door 22. Main Switch for UPS Module 1 23. Main Switch for UPS Module 2 24. Main Switch for UPS Module 3 25. Main Switch for UPS Module 4 26. Main Switch for UPS Module 5 27. Main Switch for UPS Module 6 28. Main Switch for UPS Module 7 29. Main Switch for UPS Module 8 30. Main Switch for UPS Module 9 	<ul style="list-style-type: none"> 31. Main Switch for UPS Module 10 32. RS485 port (33) RS485 port 33. Dry Contact Port 34. LCD connecting port 35. RS232 port 36. OPTION port 37. Intelligent Network Port 38. SNMP port 39. Terminal block for bypass& output 40. Terminal block for Input, battery & GND 41. Back blind cover 42. Bypass switch for power module 1 43. Bypass switch for power module 2 44. Bypass switch for power module 3 45. Bypass switch for power module 4 46. Bypass switch for power module 5 47. Bypass switch for Module 6 48. Bypass switch for Power module 7 49. Bypass switch for power module 8 50. Bypass switch for power module 9 51. Bypass switch for power module 10 52. Parallel port (54) SCI Update port 53. Bypass choke module 54. Switch for input EMI capacitance
---	--

3.3 UPS Module Appearance

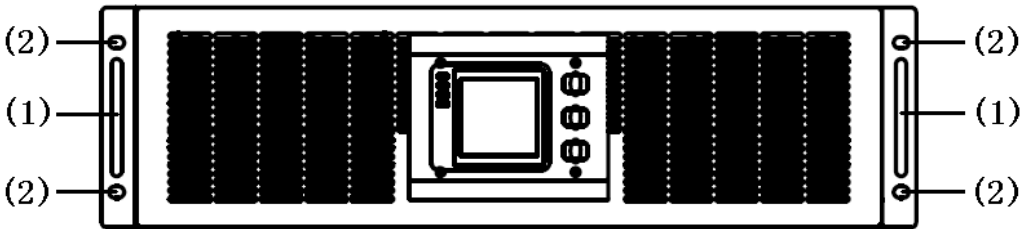

Front View

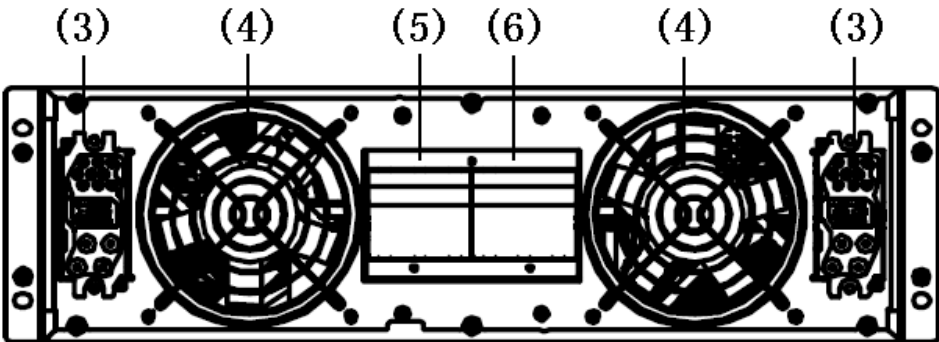

Rear View

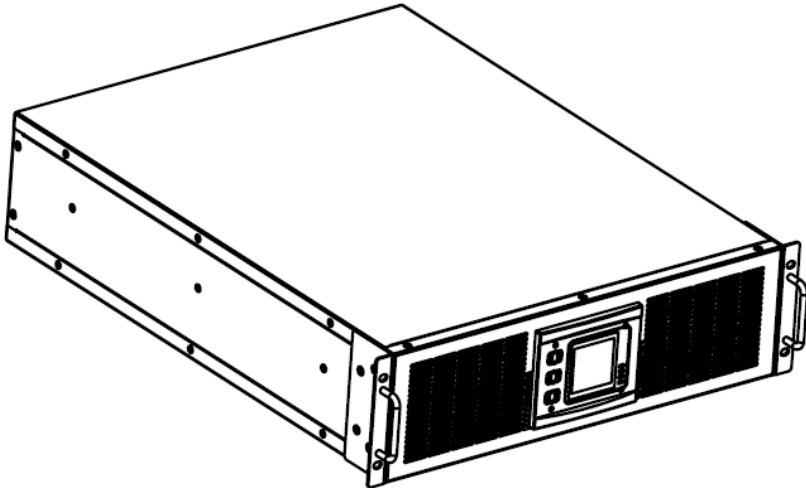

Side View

1.Handle	4. Fan
2.Screw holes	5. UPS Module input switch
3.Module connector slot	6. UPS Module bypass switch

3.4 UPS Module LCD Control Panel

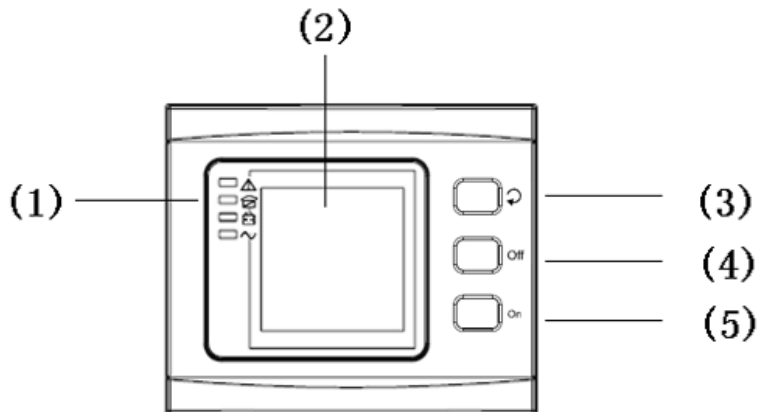

LCD control panel introduction

1. LED (from top to bottom: “alarm”, “bypass output”, “battery output”,“mains output”)
2. LCD display
3. Scroll button
4. Off button
5. On button

3.5 Installation Notes

NOTE:

Consider for the convenience of operation and maintenance, the space in front and back of the cabinet should be left at least 100cm and 80cm respectively when installing the cabinet .

- Please place the UPS in a clean, stable environment, avoid the vibration, dust, humidity, flammable gas and liquid, corrosive. To avoid from high room temperature, a system of room extractor fans is recommended to be installed. Optional air filters are available if the UPS operates in a dusty environment.
- The environment temperature around UPS should keep in a range of 0℃~40℃. If the environment temperature exceeds 40℃, the rated load capacity should be reduced by 12% per 5℃. The max temperature can't be higher than 50℃.

- If the UPS is dismantled under low temperature, it might be in a condensing condition. The UPS can't be installed unless the internal and external of the equipment is fully dry. Otherwise, there will be in danger of electric shock.
- Batteries should be mounted in an environment where the temperature is within the required specs. Temperature is a major factor in determining battery life and capacity. In a normal installation, the battery temperature is maintained between 15°C and 25°C. Keep batteries away from heat sources or main air ventilation area, etc.



WARNING!

Typical battery performance data are quoted for an operating temperature between 20°C and 25°C. Operating it above this range will reduce the battery life while operation below this range will reduce the battery capacity.

- Should the equipment not be installed immediately it must be stored in a room so as to protect it against excessive humidity and or heat sources.



CAUTION!

An unused battery must be recharged every 6 months. Temporarily connecting the UPS to a suitable AC supply mains and activating it for the time required for recharging the batteries.

- The highest altitude that UPS may work normally with full load is 1500 meters. The load capacity should be reduced when this UPS is installed in place whose altitude is higher than 1500 meters, shown as the following table:

(Load coefficient equals max load in high altitude place divided by nominal power of the UPS)

Altitude (m)	1500	2000	2500	3000	3500	4000	4500	5000
Load coefficient	100%	95%	90%	85%	80%	75%	70%	65%

- The UPS cooling is depending on fan, so it should be kept in good air ventilation area. There are many ventilation holes on the front and rear, so they should not be blocked by any exotic obstacles.

3.6 External Protective Devices

For safety reasons, it is necessary to install, external circuit breaker at the input A.C. supply and the battery. This chapter provides guidelines for qualified installers that must have the knowledge of local wiring practices for the equipment to be installed.

- **External Battery**

The UPS and its associated batteries are protected against the effect of over-current through a DC compatible thermo-magnetic circuit-breaker (or a set of fuses) located close to the battery.

- **UPS Output**

Any external distribution board used for load distribution shall be fitted with protective devices that may avoid the risk of UPS overloaded.

- **Over-current**

Protection device shall be installed at the distribution panel of the incoming main supply. It may identify the power cables current capacity as well as the overload capacity of the system .



CAUTION !

Select a thermo magnetic circuit-breaker with an IEC 60947-2 trip curve C (normal) for 125% of the current as listed below.

3.7 Power Cables

- The cable design shall comply with the voltages and currents provided in this section, Kindly follow local wiring practices and take into consideration the environmental conditions (temperature and physical support media) .



WARNING !

UPON STARTING, PLEASE ENSURE THAT YOU ARE AWARE OF THE LOCATION AND OPERATION OF THE EXTERNAL ISOLATORS WHICH ARE CONNECTED TO THE UPS INPUT/BYPASS SUPPLY OF THE MAINS DISTRIBUTION PANEL.CHECK TO SEE IF THESE SUPPLIES ARE ELECTRICALLY ISOLATED, AND POST ANY NECESSARY WARNING SIGNS TO PREVENT ANY INADVERTENT OPERATION

- For future expansion purpose, it is economical to install power cable according to the full rating capacity initially. The diameter of cable is shown bellow:

UPS cabinet	Cable Dimension			
	AC Input (mm ²)	AC Output (mm ²)	DC Input (mm ²)	Grounding (mm ²)
100KVA	50	50	75	35
200KVA	100	100	150	75



CAUTION!

Protective earth cable: Connect each cabinet to the main ground system. For Grounding connection, follow the shortest route possible.



WARNING!

FAILURE TO FOLLOW ADEQUATE EARTHING PROCEDURES MAY RESULT IN ELECTROMAGNETIC INTERFERENCE OR IN HAZARDS INVOLVING ELECTRIC SHOCK AND FIRE

3.8 Power Cable Connect

Once the equipment has been finally positioned and secured, connect the power cables as described in the following procedure.

Verify the UPS is totally isolated from its external power source and also all power isolators of the UPS are open. Check to see if they are electrically isolated, and post any necessary warning signs to prevent their inadvertent operation .

Open the UPS rear panel, remove the cover of terminals for wiring easily.

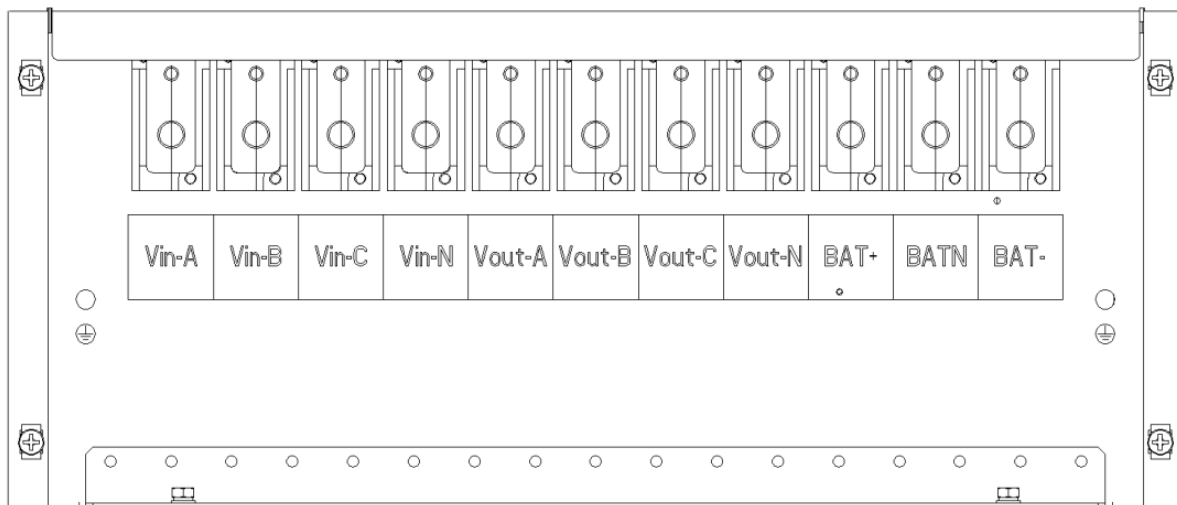

100KVA

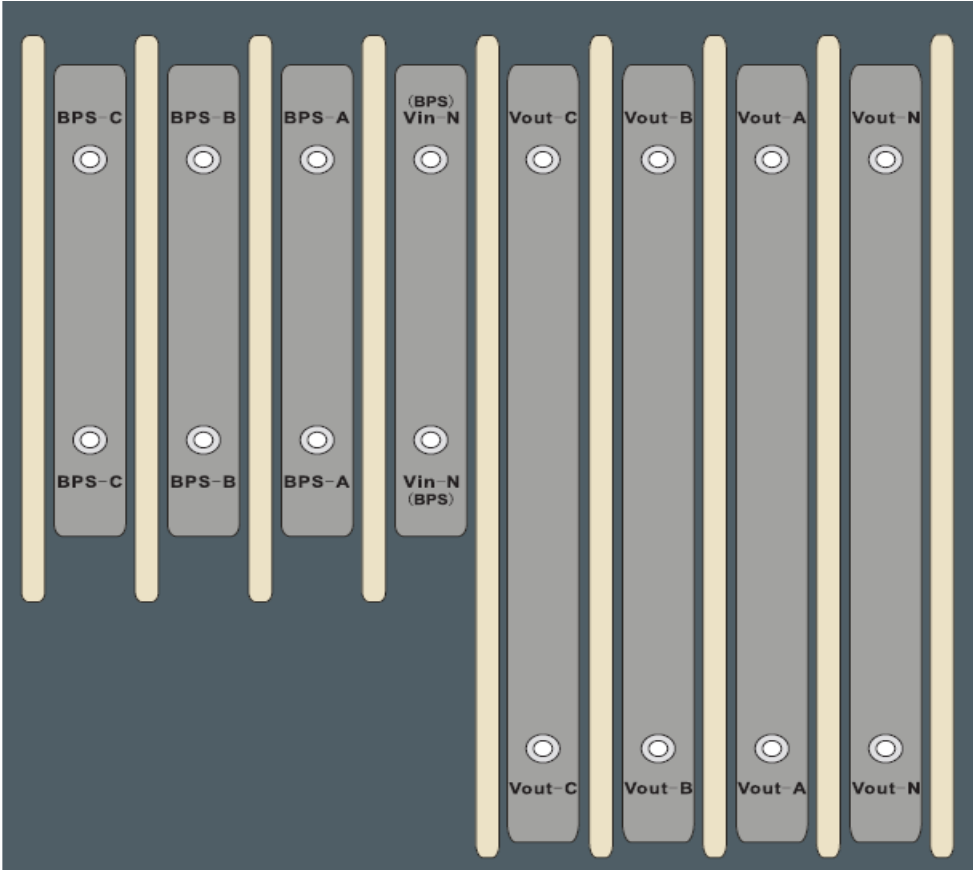

Copper bar for 200KVA bypass input,output connection

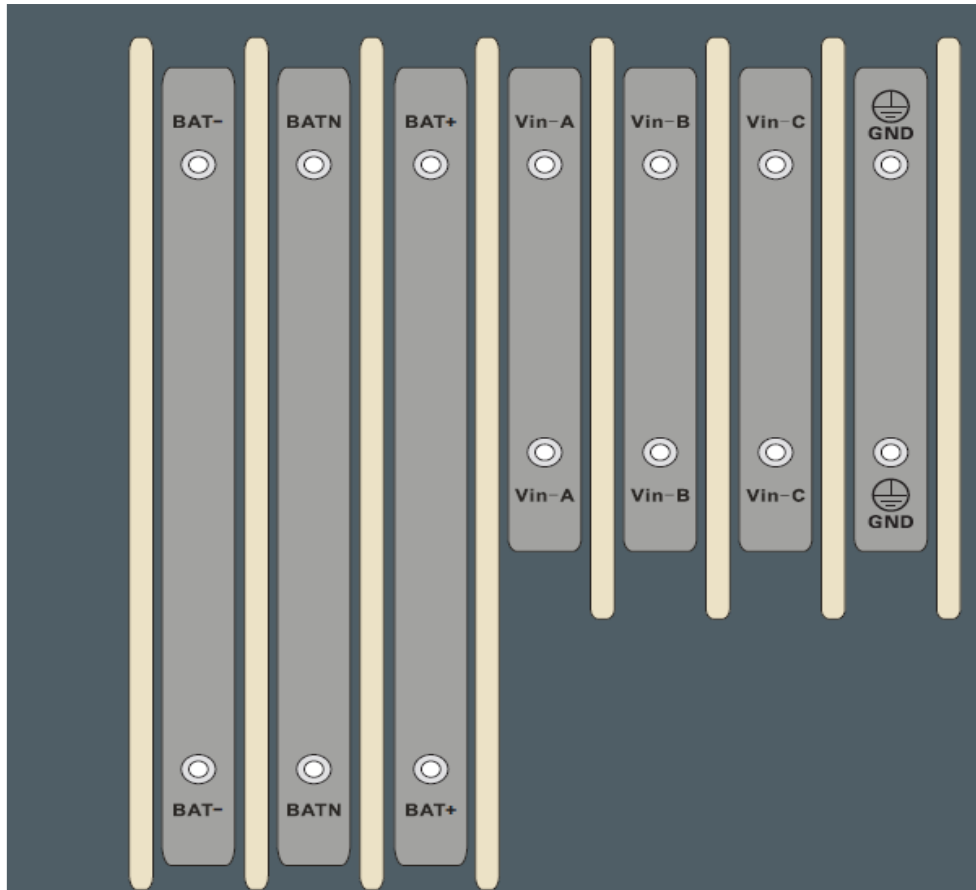

Copper bar for 200KVA battery input,AC input connection

200KVA common input connection

The common input connection configuration is provided when out of factory for this model. If this type of configuration is chosen and connect AC input to the BPS-C/BPS-B/BPS-A/Vin-N(BPS) or Vin-C/Vin-B/Vin-A/ Vin-N(BPS), tighten the connection point , the connection will be defined as a common input connection for bypass and main road.

200KVA separate bypass connection

If separate bypass configuration is used, first remove the power distribution copper strip between bypass input copper bar and mains input copper bar. The position of the copper strip is shown as below. Then connect the AC input of main road to the copper bar (Vin-C/Vin-B/Vin-A/ Vin-N(BPS)) and the bypass input to the copper bar (BPS-C/BPS-B/BPS-A/Vin-N(BPS)) . At last, tighten the connection point.

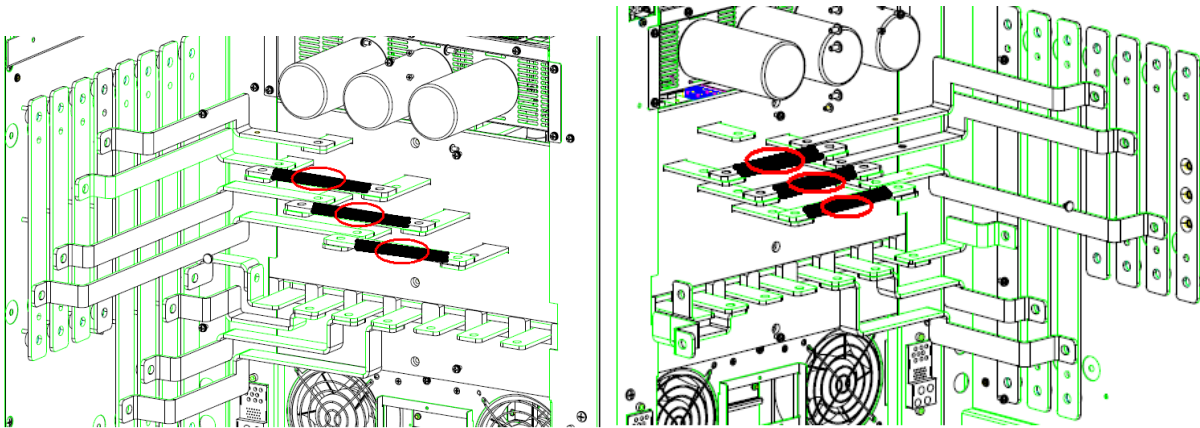

Warning !



In separate bypass connection, the power distribution copper strip between bypass input and AC input must be removed.

The AC input and bypass input must be connected to the same neutral.

Choose appropriate power cable. (Refer to the table above) and pay attention to the diameter of the connection terminal of the cable that should be greater than or equal to that of the connection poles;

WARNING!



If the load equipment is not ready to accept power on the arrival of the commissioning engineer then ensure that the system output cables are safely isolated at their ends

Connect the safety earth and any necessary bonding earth cables to the copper earth screw located on the floor of the equipment below the power connections. All cabinets in the UPS must be grounded properly.



CAUTION!

The earthing and neutral bonding arrangement must be in accordance with local and national codes of practice.

3.9 Battery Connection

The UPS adopts positive and negative double battery framework, total 32(optional 34/36/38/40) in series. A neutral cable is retrieved from the joint between the cathode of the 16th (17th/18th/19th/20th) and the anode of the 17th (18th/19th/20th/21th) of the batteries. Then the neutral cable, the battery Positive and the battery negative are connected with the UPS respectively. The battery sets between the Battery anode and the neutral are called positive batteries and that between neutral and cathode are called negative ones. The user can choose the capacity and the numbers of the batteries according to their desire. The connection is shown as following:

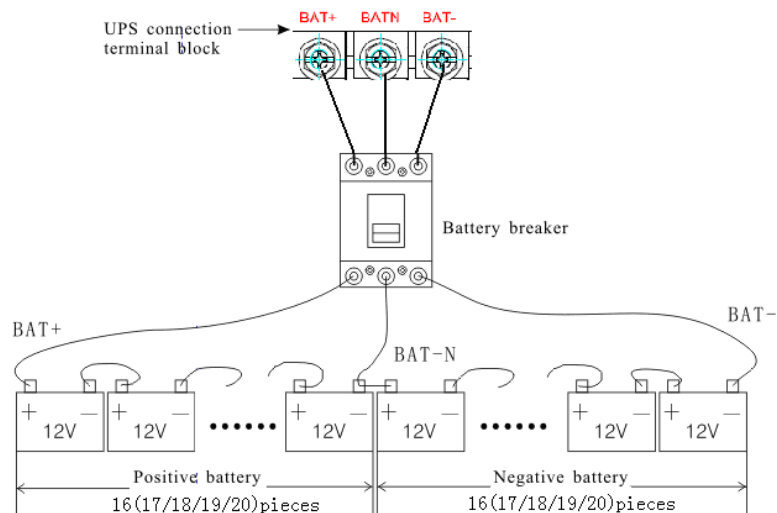

NOTE:

The BAT+ of the UPS connect poles is connected to the anode of the positive battery, the BAT- is connected to the cathode of the positive battery and the anode of the negative battery, the BATN is connected to the cathode of the negative battery.

Factory default setting for battery quantity is 32pcs and for battery capacity is 40AH (charger current 6A). connecting 34/36/38pcs or 40pcs batteries, please re-set desired battery quantity and its capacity after UPS starts at AC mode. Charger current could be adjusted automatically according to battery capacity selected. (Also charger current is selectable). Please refer to "LCD display"



CAUTION!

Ensure correct polarity battery string series connection. i.e. inter-tier and inter block connections are from (+) to (-) terminals.
Don't mix batteries with different capacity or different brands, or even mix up new and old batteries, either.



WARNING!

Ensure correct polarity of string end connections to the Battery Circuit Breaker and from the Battery Circuit Breaker to the UPS terminals i.e. (+) to (+) / (-) to (-) but disconnect one or more battery cell links in each tier. Do not reconnect these links and do not close the battery circuit breaker unless authorized by the commissioning engineer.

3.10 Online UPS Modules Replacement

For the UPS, modules must be inserted to make a complete UPS system.

The replacement of UPS module is very simple and can be operated online. The control system of the UPS can detect the inserted or removed module(s) automatically. The user may operate easily by following the steps mentioned below.

- **NOTE: The UPS module is rather heavy, please move it by two people!**

- **Insert module**

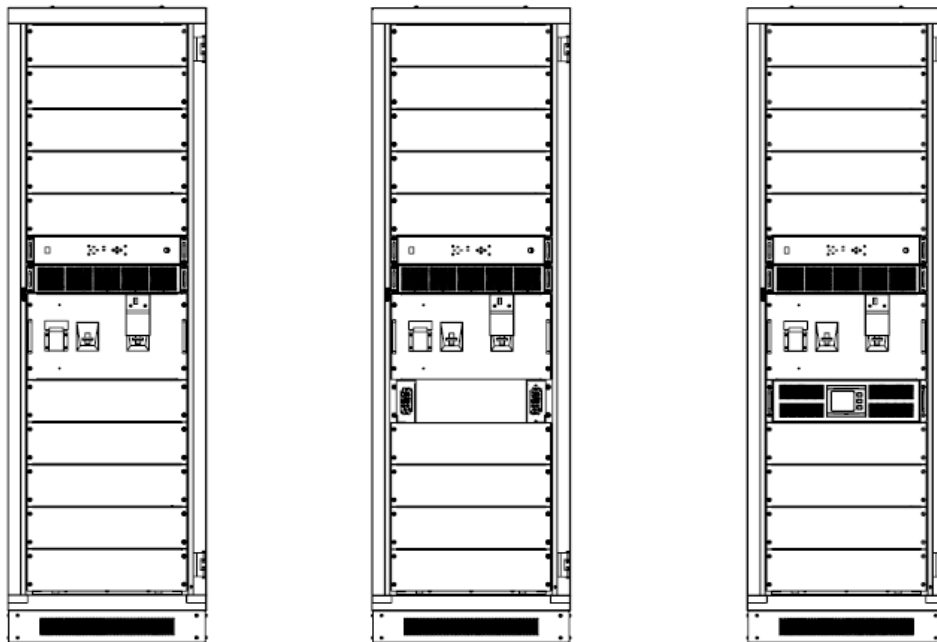

Remove
Decorating Panel

Insert UPS
Module

Fix with
Screw

1. Remove decorated panel;
2. Put the UPS module in the cabinet module slot. Push the module along the slot into the cabinet until the module is inserted properly.
3. Fix the module with screws (M5) at the positioning screw holes;
4. Open input switch at modules' rear panel, and output switches accordingly. (From bottom to top, the order is 1-5 or 10)
5. After the modules start up, the system will detect the modules inserted automatically, and parallel up the modules into whole system.

- **Remove UPS module**

Remove the coronal screws on the left side of the module to stop the module running completely and remove the module after fan stop spinning.

WARNING!

1. Make sure the LCD screen is totally off before removing the module; otherwise, electric sparks will occur at the connection of module and system cabinet.
2. The coronal screw at left side of the module controls the operation of the module. Only after the screw is tightened, the module can start running. When insert new module, make sure the screw is tightened properly.
3. When insert the module under battery mode, please press “ON” button at module’s LCD panel until the module starts.

3.11 UPS Multi-Module Installation

The basic installation procedure of a parallel system comprising two or more UPS is the same as that of single. The following sections introduce the installation procedures specified to the parallel system.

3.11.1 Cabinet Installation

Connect all the UPS needed to be put into parallel system as below picture.

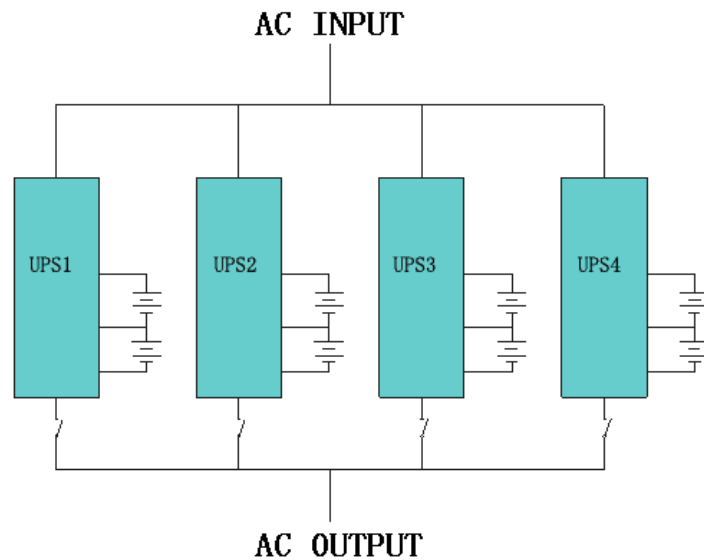

(Make sure each UPS input breaker is in “off” position and there is no any output from each UPS connected. Battery groups can be connected separately or in parallel, which means the system itself provides both separate battery and common battery.)

WARNING!



Make sure the N,A (L1) ,B (L2) ,C (L3) lines are correct, and grounding is well connected.

3.11.2 Parallel Cable Installation

Shielded and double insulated control cables available must be interconnected in a ring configuration among UPS modules as shown below. The parallel control board is mounted on each UPS. The ring configuration ensures high reliability of the control.

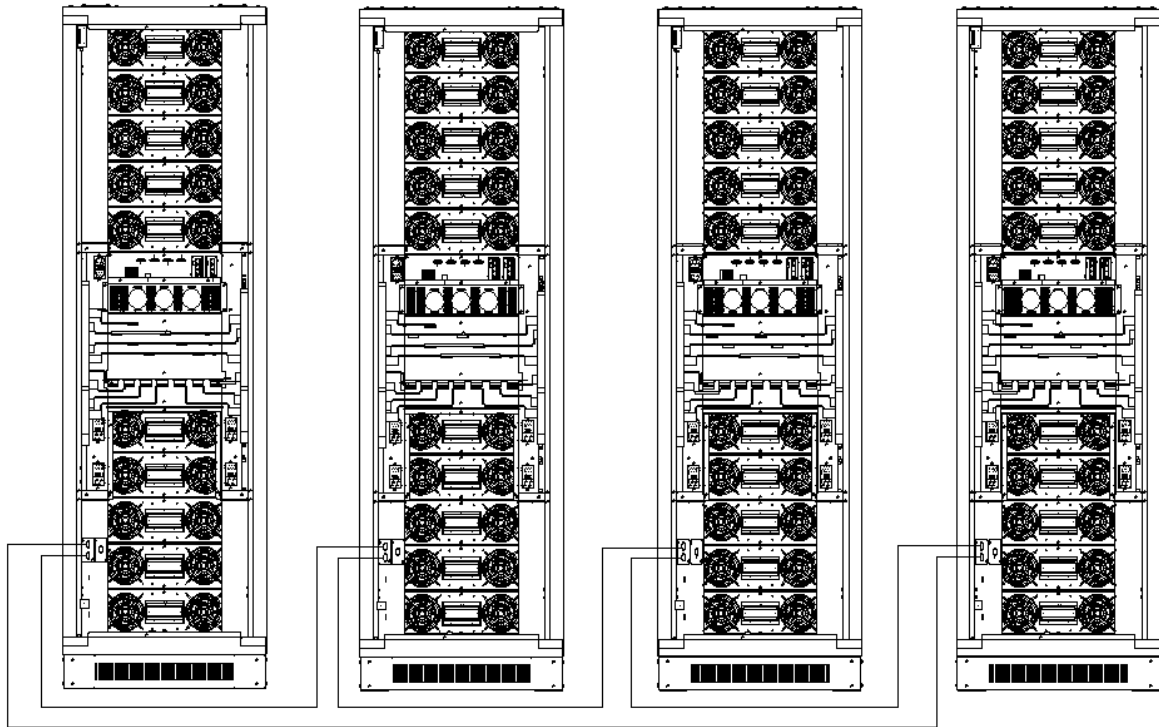

Parallel board position for 2m cabinet

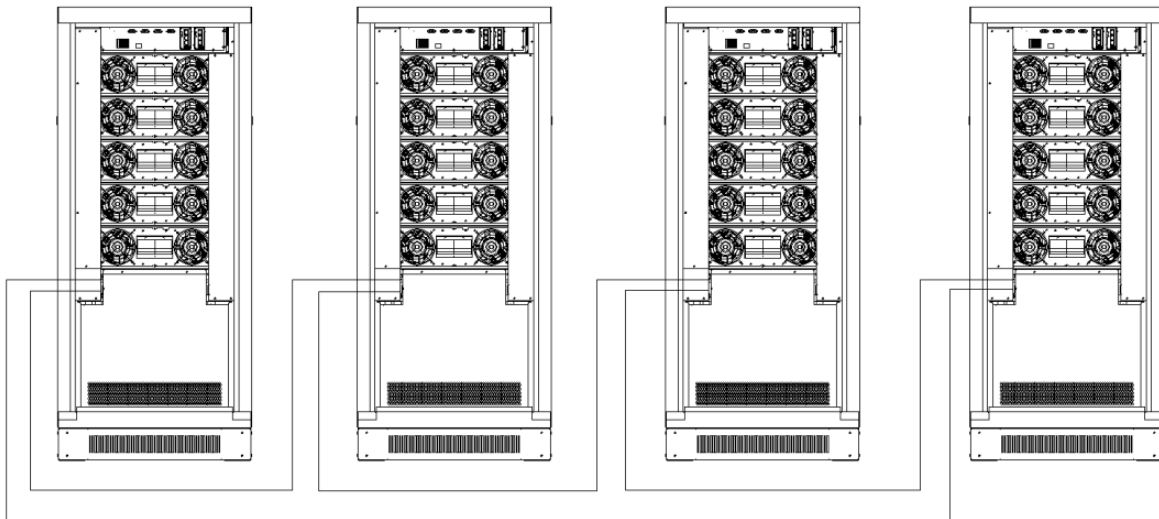

PDU parallel board position for 1.4m cabinet

3.11.3 Parallel Board Jumper Modification

When finish connecting the parallel cables, the PDU baffle or right panel should be removed: modify each jumper of the parallel board (MHTBSHR1CX01/MHDBGHR1CM06). Different cabinets can refer to the following Figures.

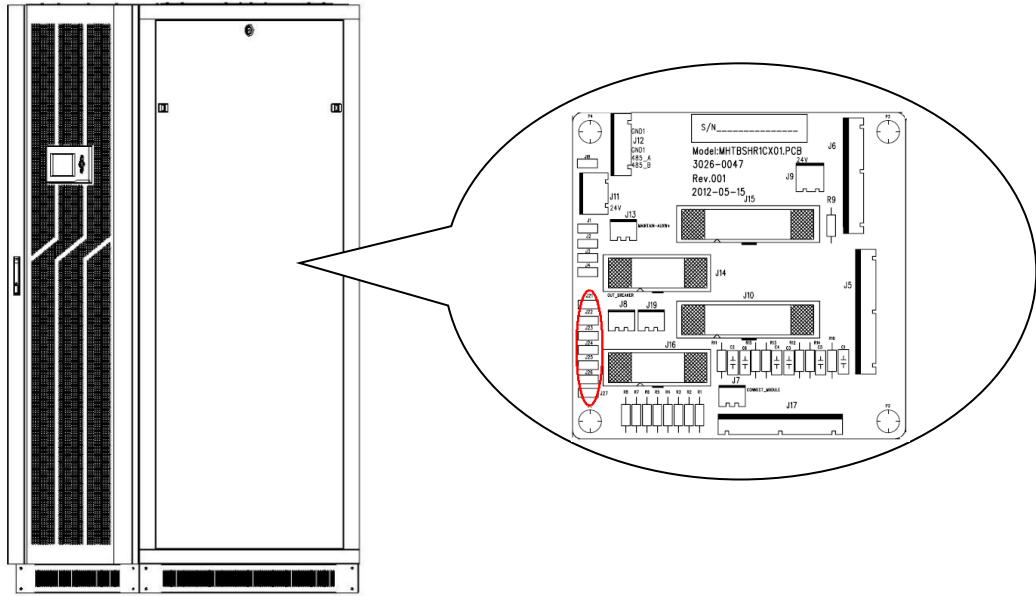

Paralle board position for 2m cabinet

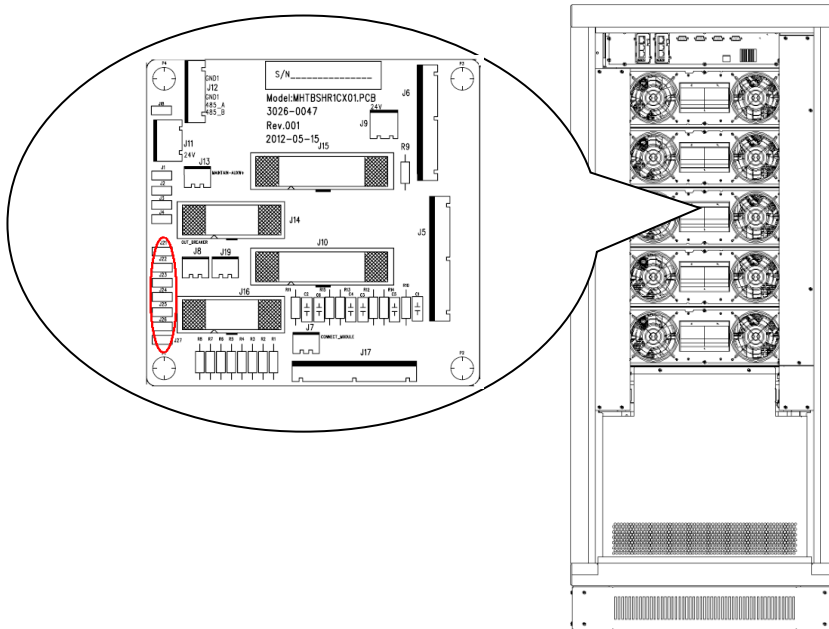

Parallel board position for 1.4m cabinet



CAUTION !

When two 2m cabinets connected in parallel, remove the jumper J25 and J26 of all the parallel boards (MHTBSHR1CX01) ; when 3 or 4 cabinets in parallel, remove J25, J26 and J27 of all the parallel boards (MHTBSHR1CX01)

When two 1.4m cabinets connected in parallel, remove the jumper J21, J22, J23 and J24 of all the parallel boards (MHTBSHR1CX01) ; when 3 or 4 cabinets in parallel, remove J21, J22, J23, J24, J25 and J26 of all the parallel boards (MHTBSHR1CX01) .

3.11.4 Requirement for the Parallel System

A parallel system behaves as a large UPS but with the advantage of presenting higher reliability. In order to assure that all UPS are equally utilized and comply with relevant wiring rules, please follow the requirements below:

1. All UPS must be of the same rating and be connected to the same source.
2. Bypass input and AC input of main road must be connected to the same Neutral
3. The outputs of all the single UPS must be connected to a common output bus.
4. The length and specification of power cables including the bypass input cables and the UPS output cables should be the same. This facilitates load sharing when operating in bypass mode.

4 OPERATION

4.1 Operation Modes

The UPS is a double-conversion on-line UPS that may operate in the following alternative modes:

- **Normal mode**

The rectifier/charger derives power from the AC Mains and supplies DC power to the inverter while floating and boosting charge the battery simultaneously. Then, the inverter converts the DC power to AC and supplies to the load.

- **Battery mode (Stored Energy Mode)**

If the AC mains input power fails, the inverter, which obtains power from the battery, supplies the critical AC load. There is no power interruption to the critical load. The UPS will automatically return to Normal Mode when AC recovers.

- **Bypass mode**

If the inverter is out of order, or if overload occurs, the static transfer switch will be activated to transfer the load from the inverter supply to bypass supply without interruption to the critical load. In the event that the inverter output is not synchronized with the bypass AC source, the static switch will perform a transfer of the load from the inverter to the bypass with power interruption to the critical AC load. This is to avoid paralleling of unsynchronized AC sources. This interruption is programmable but typically set to be less than an electrical cycle e.g. less than 15ms (50Hz) or less than 13.33ms (60Hz).

- **Maintenance mode (Manual Bypass)**

A manual bypass switch is available to ensure continuity of supply to the critical load when the UPS is out of order or in repair. This manual bypass switch is fitted for all UPS modules and bears for equivalent rated load.

- **Redundancy mode**

Based on different demands, The UPS can be set as N+X redundancy mode to increase the reliability to the load connected.

4.2 Turn on/off UPS

4.2.1 Restart Procedure



CAUTION!

MAKE SURE GROUNDING IS PROPERLY DONE!

- Set the Battery Breaker to the “ON” position according to the user’s manual.
- Open the front and rear doors of the UPS to access to the main power switches. During this procedure the output terminals will become alive.



CAUTION !

Check to see if the load is safely connected with the output of the UPS. If the load is not ready to receive power from the UPS, make sure that it is safely isolated from the UPS output terminals

- Check the status of the power switch of the monitoring module. Default is set at “ON”.

Monitoring module power supply switch



Turn ON the power switch of the monitoring module, so that the UPS system can communicate normally through the monitoring unit. When hot-swap this monitoring unit, the power switch must be OFF.

- Turn ON the input and bypass switches of all UPS modules, which locate at the modules’ rear panels.

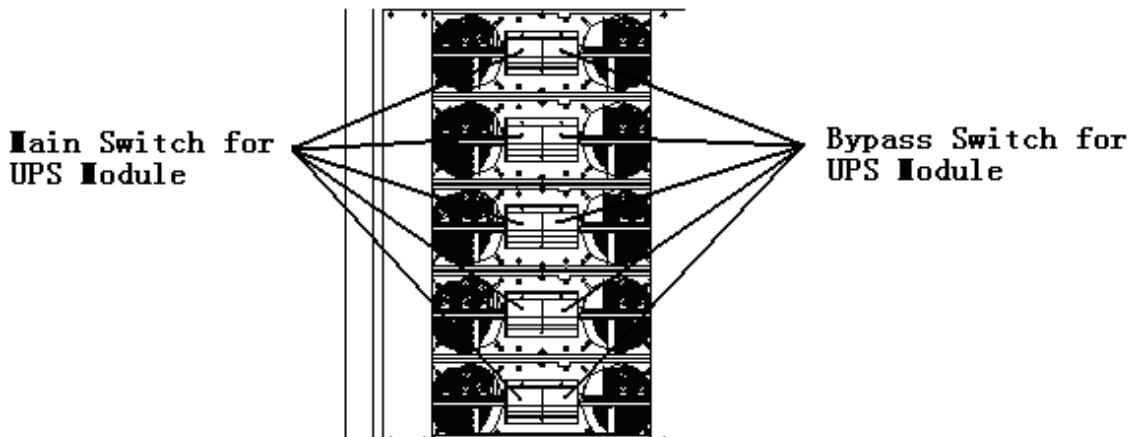

When AC MAINS input voltage within the range, And the rectifiers of the UPS will be started up in 30 seconds, then the inverter is started completely. When the output breaker is “ON”, the inverter LED lights up.

- Switch ON all output breakers, which locate at module’s front panel.



If the rectifier of the module does not start-up, the bypass LED will light up. When the inverter is on, the UPS will transfer from bypass mode to inverter mode, then the bypass LED is off and the inverter LED is on.

No matter the UPS is operated normally or not, the LCD display will indicate current status.

4.2.2 Test Procedure



CAUTION!

The UPS is operating normally. It may take 60 seconds to boost up the system and perform self-test completely.

- Switch off the MAINS to simulate utility failure, the rectifier will turn off and the battery should feed the inverter without interruption. At this time, the LEDs of battery should be turned on.
- Switch on the MAINS to simulate utility recovery, the rectifier will restart automatically after 20 seconds and the inverter will supply to the load. It is suggested to use Dummy loads for testing. The UPS can be loaded up to its maximum capacity during load test.

4.2.3 Black (Cold) Start Procedure

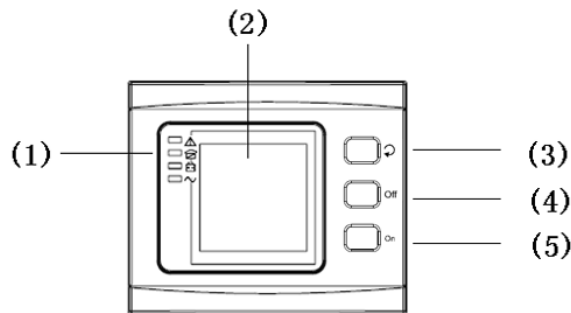

CAUTION!

Follow these procedures when the input AC Utility Failure, but battery is normal

- Turn on the battery switch.
The battery will feed the Auxiliary power board.
- Turn on the Output switch
- Trigger the cold start buttons of the modules respectively as the position 5 of the above

Drawing :

When battery normal, rectifier starts operation, 30s later, inverter starts and operates and battery LED on



CAUTION!

Wait for approximately 30 seconds before you press the black start key

4.2.4 Maintenance Bypass

To supply the load via Mains, you may simply active the internal mechanical bypass switch.



CAUTION!

The load is not protected by the UPS when the internal mechanical bypass system is active and the power is not conditioned.

Switch to mechanical bypass



CAUTION!

If the UPS is running normally and can be controlled through the display, carry out steps 1 to 5; otherwise, jump to Step 4.

- Open the cover of maintenance switch, the UPS turns to bypass mode automatically.
- Turn on MAINTANCE breaker;
- Open BATTERY breaker;
- Switch OFF the MAINS breakers of all modules
- Open all OUTPUT breakers;

At this time the bypass source will supply to the load through the Maintenance breaker.

Switch to normal operation (from mechanical bypass)



CAUTION!

Never attempt to switch the UPS back to normal operation until you have verified that there are no internal UPS faults

- Open the front and rear doors of the UPS to be easily access to the main power switches
- Switch ON the output breakers of the modules.
- Switch ON the input breakers of the modules.

The UPS powers from the static bypass instead of the maintenance bypass, then the bypass LED will light up.

- Switch OFF the maintenance bypass breaker, then the output is supplied by the bypass of the modules.
- Put on the maintenance switch cover.

The rectifier will operate normally after 30 seconds. If the inverter works normally, the system will be transferred from bypass mode to normal mode.

4.2.5 Shut Down Procedure



CAUTION!

This procedure should be followed to completely shut down the UPS and the LOAD. After all power switches, isolators and circuit breakers are opened, there will be no output.

- Press the INVERTER OFF button on the right side of the operator control panel for about two seconds ;
- The Inverter LED will be extinguished and audible alarm comes simultaneously.
- Open the BATTERY breaker ;
- Open the UPS door to easily access to the main power switch ;
- Switch OFF the input breakers of all modules.
- Open the OUTPUT power switch. The UPS shuts down ;
- To completely isolate the UPS from AC Mains, all input switches of Utility shall be completely off, which includes the ones for rectifier and bypass.
- The primary input distribution panel, which is often located far away from the UPS area, so a label should be posted to advise service personnel that the UPS circuit is under maintenance.



WARNING!

Wait for about 5 minutes for the internal D.C. bus bar capacitors to be completely discharged.

4.2.6 Startup Procedure for Parallel System

1. Connect parallel cable, input/output cable, battery cable well; modify the parallel board jumpers correctly.
2. Measure the positive and negative battery pack voltage. Battery breaker is opened temporarily.
3. Check if the power switch of monitoring module is closed. The default is closed.
4. Close the output switch of power distribution unit at the front door.
5. According to the startup procedure for single unit, set the operation mode of each UPS: single mode is changed to parallel mode; set the parallel number for each UPS; up to 4 units can be parallel; set the ID of each cabinet, the ID of each unit must be different.
6. Close the breakers of all the power module. Close the external input switch and start from mains.
7. After start from mains, check the LCD interface of each UPS to see if the ID, VA is the same with the actual values.
8. Close the external battery breaker of each UPS. Check if the charging current displayed in LCD is normal.



NOTE

The UPS cannot be parallel until each single unit is normal.

4.3 The Display

4.3.1 System LCD Display

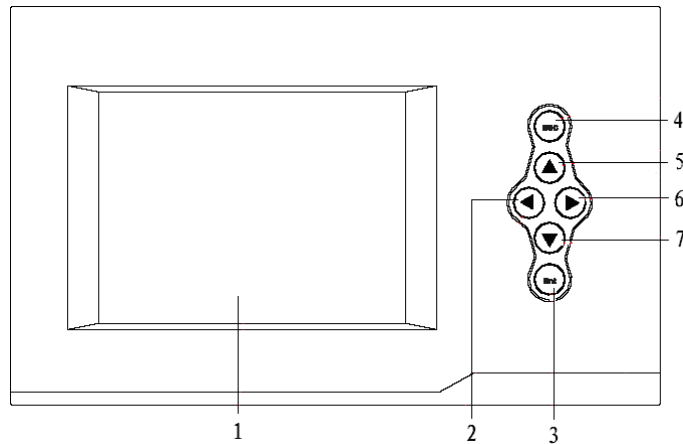

Overview of the operating panel of the UPS

1. Touch LCD screen :monitoring of all measured parameters, UPS and Battery status and event and alarm logs
2. LEFT KEY: turn left or scroll up
3. ENT KEY: enter the items or ensure the select
4. ESC KEY: exit the items or cancel
5. UP KEY: scroll up
6. RIGHT KEY: turn right or scroll down
7. DOWN KEY: scroll down

Introduction



CAUTION!

The display provides more functions than those described in this manual.

100KVA On-Line 12						
ID:01						
◀	Output	Module	Input	Batt	State	▶
A B C						
Phase Voltage(v)			220	221	221	
Phase Current(A)			16	10	18	
Frequency(Hz)			50			
Active Power(kw)			5.0	5.2	5.6	
Apparent Power(KVA)			3.7	3.9	4.1	
Load percent(%)			50	52	53	
Load Peak Rate			1.3	1.5	1.8	

Output data

100KVA On-Line 12						
ID:01						
◀	Output	Module	Input	Batt	State	▶
		Module01			Online	
		Module02			Online	
		Module03			Online	
		Module04			Online	
		Module05			Online	
		Module06			Offline	
		Module07			Offline	
		Module08			Offline	
		Module09			Offline	
		Module10			Offline	

Modules data

100KVA On-Line 12						
ID:01						
◀	Output	Module	Input	Batt	State	▶
Module01						
Invert Voltage(V)			220	220	220	
Invert Current(A)			0	0	0	
Frequency(HZ)			50			
Positive Bus Voltage(V)				390		
Negative Bus Voltage(V)				390		
Code	8000-8000		D800-8000			
	0000-0000		0000-0000			
Back						

Detailed module data

100KVA On-Line 12						
ID:01						
◀	Output	Module	Input	Batt	State	▶
Mains						
A B C						
Phase Voltage(V)			220	220	220	
Phase Current(A)			2	2	2	
Frequency(HZ)			50			
Bypass						
Phase Voltage(V)			220	220	220	
Frequency(HZ)			50			

Input data

100KVA On-Line 12						
ID:01						
◀	Output	Module	Input	Batt	State	▶
Positive Battery Voltage (V)				239.9		
Negative Battery Voltage (V)				241.0		
Positive Battery Current (A)				15.1		
Negative Battery Current (A)				14.8		
Battery State				Charge		
Battery Temperature (°C)				0.0		
Lasting(min)				0		

Battery data

100KVA On-Line 12						
ID:01						
◀	Output	Module	Input	Batt	State	▶
Input Switch					ON	
Output Switch					ON	
Bypass Switch					OFF	
Manu-Bypass Switch					OFF	
Inside Temperature (°C)					30	

Status data

100KVA On-Line 12					
ID:01		Command	Setting	Record	Version
Battery Test Buzzer Set ON Default Set					

Command data

100KVA On-Line 12					
ID:01		Command	Setting	Record	Version
Language/English Change Password Date Setting 2012-05-23 08:00 Back-Light Delay 10 min Contrast 20 Self-Test Date disable Timing of ON/OFF disable Back Next					

Setting data1

100KVA On-Line 12					
ID:01		Command	Setting	Record	Version
Work Mode Parallel System Voltage Level 220V System Frequency Level 50HZ Auto Turn-on Enable Bypass Frequency Range 10% Bypass Volt. Upper Limit 15% Back Bypass Volt. Lower Limit -45% O/P Volt Regulation 0% Next					

Setting data2

100KVA On-Line 12					
ID:01		Command	Setting	Record	Version
Parallel ID 01 UPS Output Enable Float Volt Revise 0.001 Parallel Amount 04 Internal Module amount 05 Back Next					

Setting data3

100KVA On-Line 12					
ID:01		Command	Setting	Record	Version
Single Battery Volt. 12V Battery Number 20 Battery Group 1 Single Battery Capa. 100AH Boost Upper Limit Volt. 2.31 Float Base Volt. 2.25 Battery Protect Volt. 1.70 Boost Charge Enable Back Boost Last Time 231 Min Max Charge Current 25A Next					

Setting data4

100KVA On-Line 12					
ID:01		Command	Setting	Record	Version
0004 05-23 07:16:05 On Line 0002 05-23 07:16:01 Back Normal 0003 05-23 07:06:00 Int.Input Switc.. 0004 05-23 07:00:00 Int.Bypass Swit.. .. Back Next					

Record data

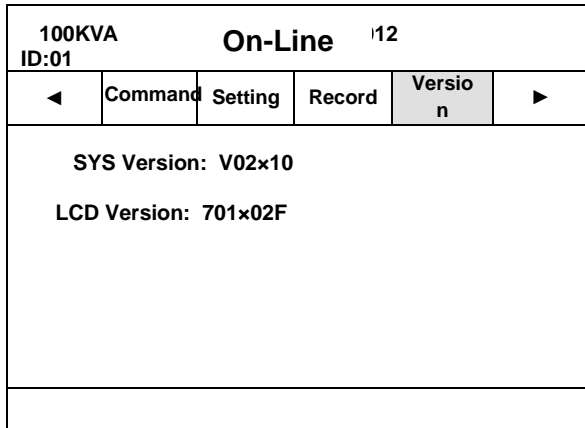

Version data

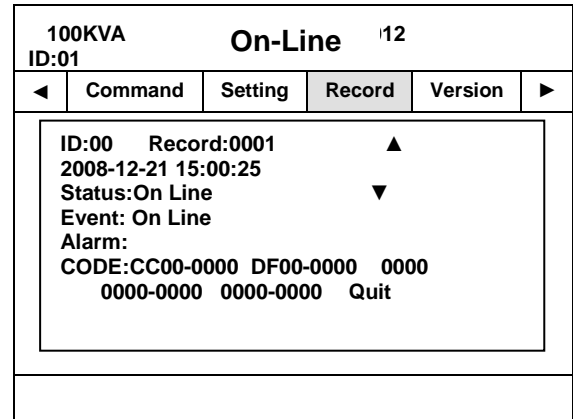

Module detailed record data

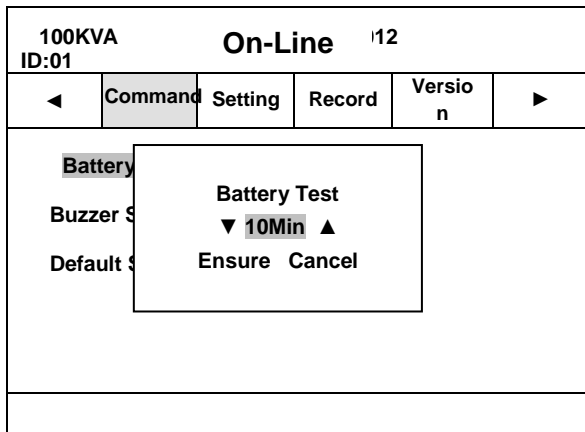

Setting of battery test

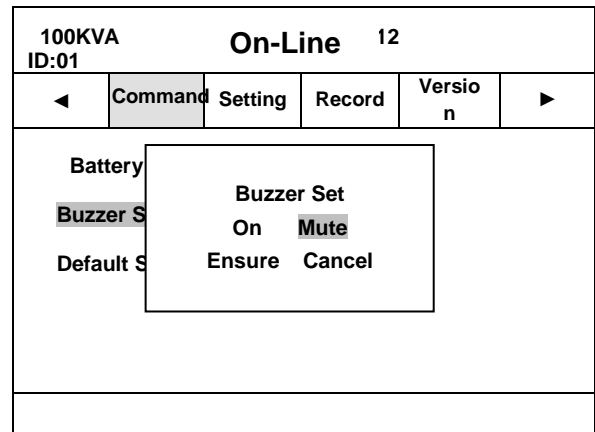

Setting of Buzzer

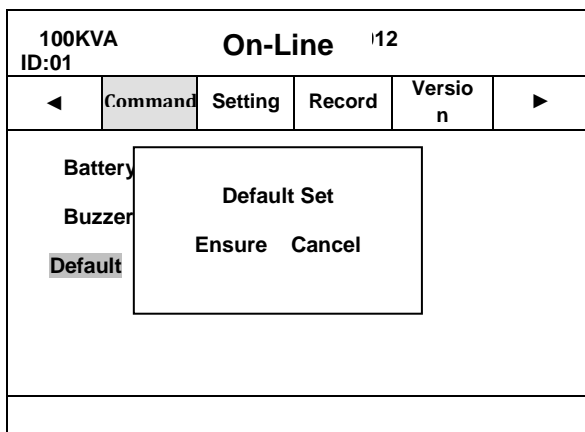

Restore default setting

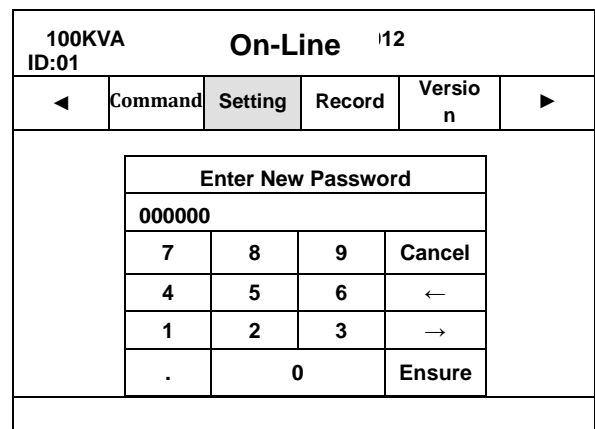

Password setting

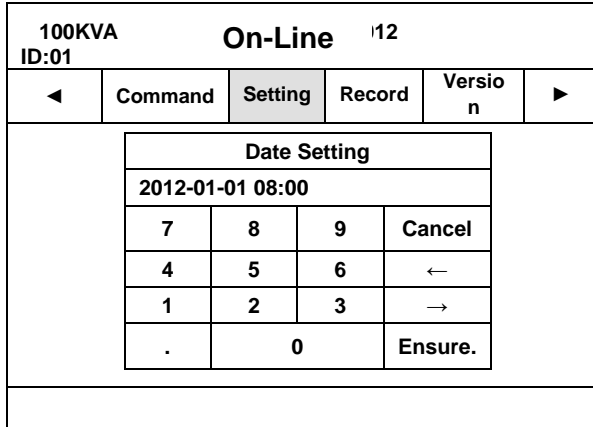

Date setting

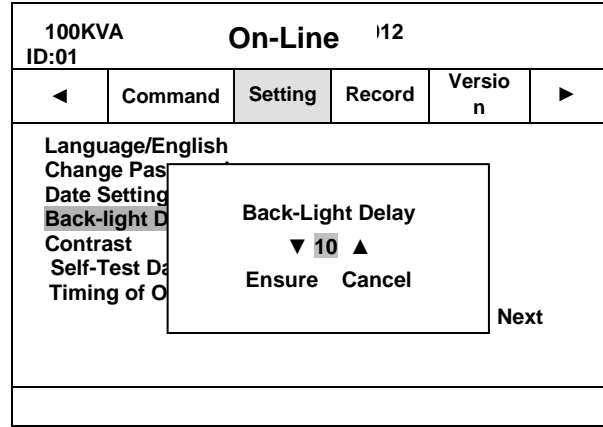

Back-Light Delay setting

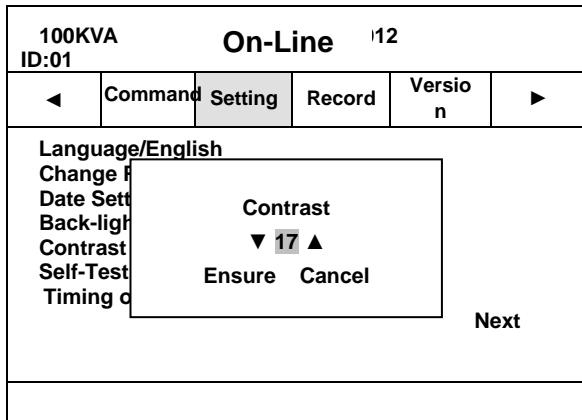

Contrast setting

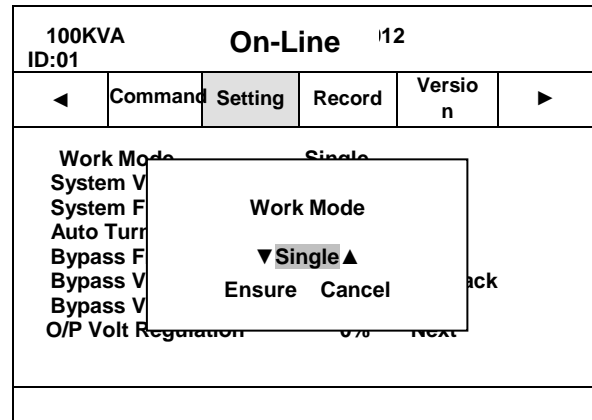

Setting of work mode

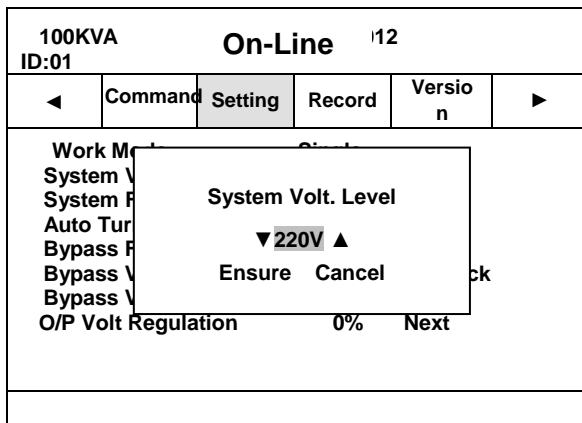

Setting of system volt. Level

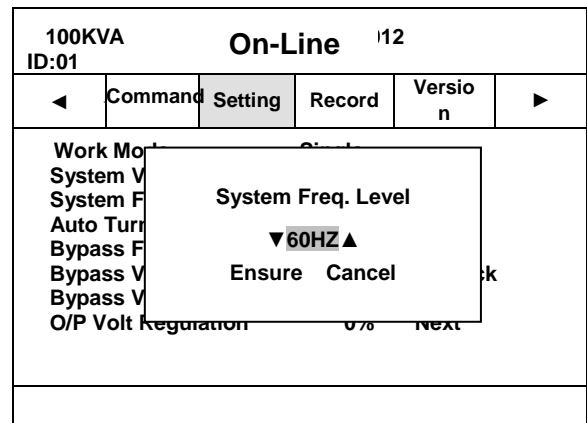

Setting of system freq. level

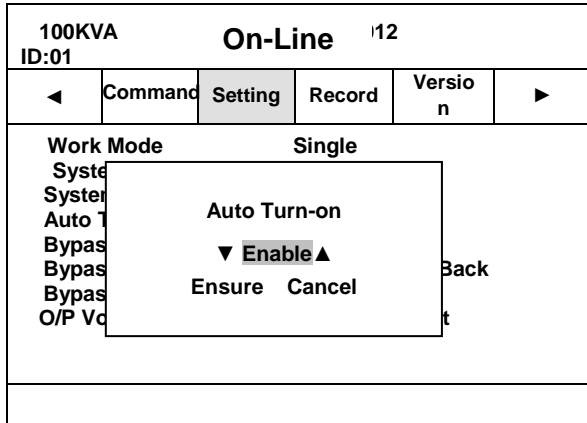

Setting of auto turn-on

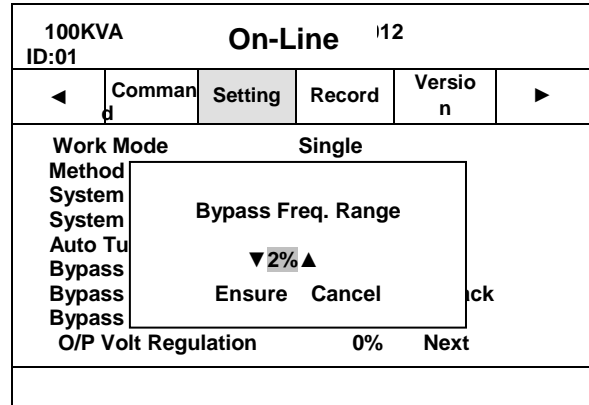

Setting of bypass freq.rang

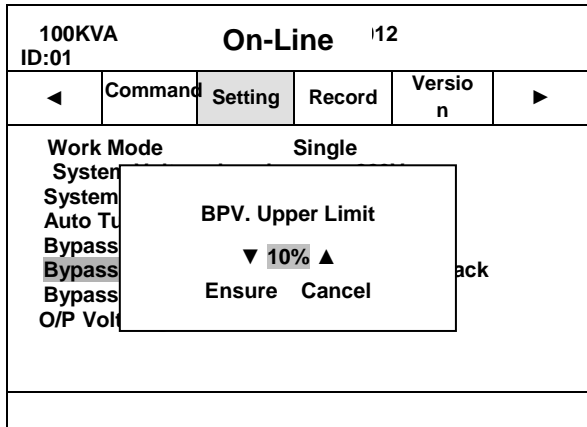

Setting of bypass volt. Upper limit

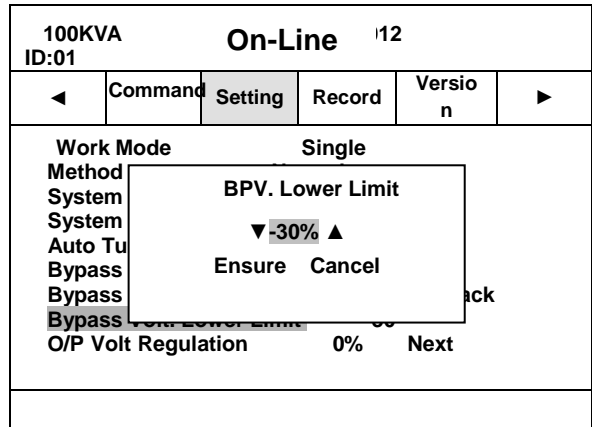

Setting of bypass volt. Lower limit

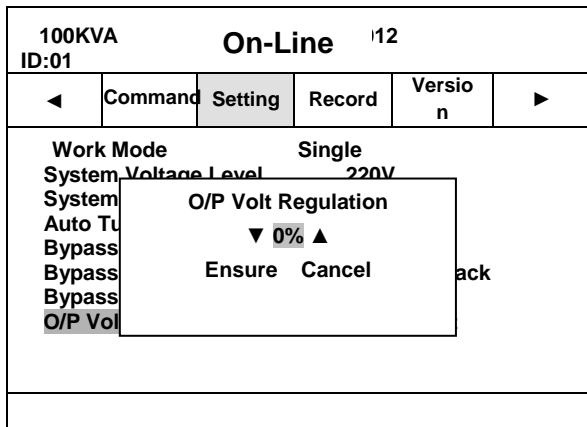

Setting of output volt. Regulation

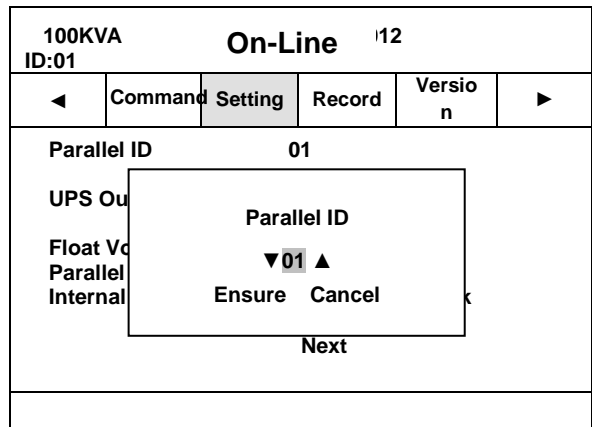

Whole system ID (parallel ID) setting

100KVA ID:01		On-Line		12	
◀	Command	Setting	Record	Versio n	▶
Parallel ID		01			
UPS Outp	<div style="border: 1px solid black; padding: 5px; text-align: center;"> Float Volt Revise ▼ 0.000 ▲ Ensure Cancel </div>				
Float Volt					
Parallel A					
Internal M					
Next					

Setting of float charge volt. Compensation factor

100KVA ID:01		On-Line		12	
◀	Command	Setting	Record	Versio n	▶
Parallel ID		01			
UPS Outp	<div style="border: 1px solid black; padding: 5px; text-align: center;"> Parallel Amount ▼ 01 ▲ Ensure Cancel </div>				
Float Volt					
Parallel A					
Internal M					
Next					

Setting of parallel modules amount

100KVA ID:01		On-Line		12	
◀	Command	Setting	Record	Versio n	▶
Parallel ID		01			
UPS O	<div style="border: 1px solid black; padding: 5px; text-align: center;"> Internal Module amount ▼ 00 ▲ Ensure Cancel </div>				
Float V					
Paralle					
Interna					
Next					

Setting of internal module amount

100KVA ID:01		On-Line		12	
◀	Command	Setting	Record	Versio n	▶
Single Battery Volt.		12V			
Battery N	<div style="border: 1px solid black; padding: 5px; text-align: center;"> Single Battery Volt. ▼ 6V ▲ Ensure Cancel </div>				
Battery G					
Single Ba					
Boost Up					
Boost Last Time	231 Min				
Max Charge Current	25A		Next		

Setting of single battery voltage

100KVA ID:01		On-Line		12	
◀	Command	Setting	Record	Versio n	▶
Single Battery Volt.		12V			
Battery	<div style="border: 1px solid black; padding: 5px; text-align: center;"> Battery Number ▼ 20 ▲ Ensure Cancel </div>				
Battery					
Single					
Boost U					
Boost Last Time	231 Min				
Max Charge Current	25A		Next		

Setting of battery number

100KVA ID:01		On-Line		12	
◀	Command	Setting	Record	Versio n	▶
Single Battery Volt.		12V			
Battery	<div style="border: 1px solid black; padding: 5px; text-align: center;"> Battery Group ▼ 1 ▲ Ensure Cancel </div>				
Battery					
Single E					
Boost U					
Boost Last Time	231 Min				
Max Charge Current	25A		Next		

Setting of battery group

100KVA ID:01		On-Line		V12	
◀	Command	Setting	Record	Version	▶
Single Battery Capa.					
0100					
7	8	9	Cancel		
4	5	6	←		
1	2	3	→		
.	0		Ensure		

Setting of single battery capacity

100KVA ID:01		On-Line		V12	
◀		Setting	Record	Version	▶
Single Battery Volt. 12V					
Max Charge Current					
▼ 25 ▲					
Ensure Cancel					
Boost Last Time 231 Min					
Max Charge Current 25A Next					

Setting of max. Charge current

100KVA ID:01		On-Line		V12	
◀	Command	Setting	Record	Version	▶
Single Battery Volt. 12V					
Float Base Volt.					
▼ 2.28 ▲					
Ensure Cancel					
Boost Last Time 231 Min					
Max Charge Current 25A Next					

Setting of float base charge voltage

100KVA ID:01		On-Line		V12	
◀	Command	Setting	Record	Version	▶
Single Battery Volt. 12V					
Bat. Protect Volt.					
▼ 1.28 ▲					
Ensure Cancel					
Boost Last Time 231 Min					
Max Charge Current 25A Next					

Setting of Battery Protect Voltage

100KVA ID:01		On-Line		V12	
◀	Command	Setting	Record	Version	▶
Single Battery Volt. 12V					
Boost Charge					
▼ Enable ▲					
Ensure Cancel					
Boost Last Time 231 Min					
Max Charge Current 25A Next					

Setting of boost charge

100KVA ID:01		On-Line		V12	
◀	Command	Setting	Record	Version	▶
Single Battery Volt. 12V					
Boost Last Time					
▼ 231 ▲					
Ensure Cancel					
Boost Last Time 231 Min					
Max Charge Current 25A Next					

Setting of boost charge lasting time

100KVA ID:01		On-Line		12	
◀	Command	Setting	Record	Versio n	▶
Single Battery Volt.		12V			
Battery Number		20			
Battery		<div style="border: 1px solid black; padding: 5px; text-align: center;"> Boost Upper Limit Volt. ▼ 2.32 ▲ Ensure Cancel </div>			
Single					
Boost U					
Float B					
Battery					
Boost C					
Boost L					
Max Charge Current		25A		Next	

Setting of boost Upper Limit Volt

4.3.2 UPS Module LCD Display

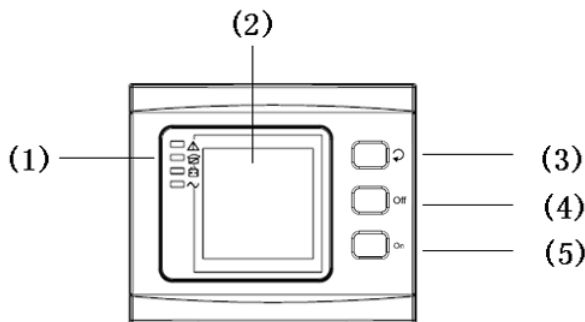

Overview of the operating panel of the UPS

1. LED indicator
2. LCD Display
3. scroll button: enter to next item
4. OFF button :
5. ON button:

Introduction



CAUTION!

The display provides more functions than those described in this manual.

There are 16 interfaces available in the LCD display:

Item	Interface Description	Content Displayed
01	CODE	Operational status and mode
02	Input A(Input L1)	Voltage & Frequency
03	Input B(Input L2)	Voltage & Frequency
04	Input C(Input L3)	Voltage & Frequency
05	Bat. +	Voltage & Current
06	Bat. -	Voltage & Current
07	Output A(Output L1)	Voltage & Frequency
08	Output B(Output L2)	Voltage & Frequency
09	Output C(Output L3)	Voltage & Frequency
10	Load A	Load
11	Load B	Load
12	Load C	Load
13	Total Load	Load
14	Temperature	Internal temperature and ambient temperature
15	Software version & model	Version of rectifier software, version of inverter software, model
16	CODE	Alarm Code(Warning Message)

- 1 When the UPS is connecting with the Utility or Battery at cold start mode, it shows as drawing below:

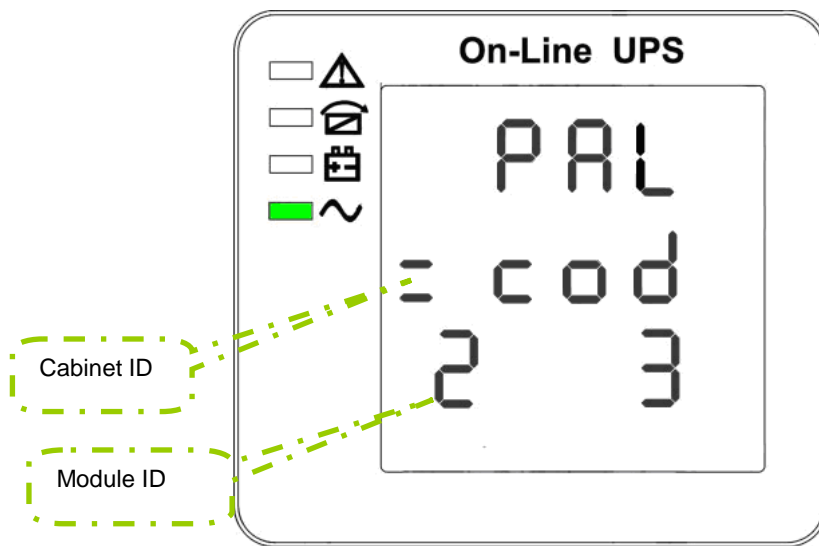

1. module ID and status code

2 Press "scroll" button, the UPS goes to next page as shown below.

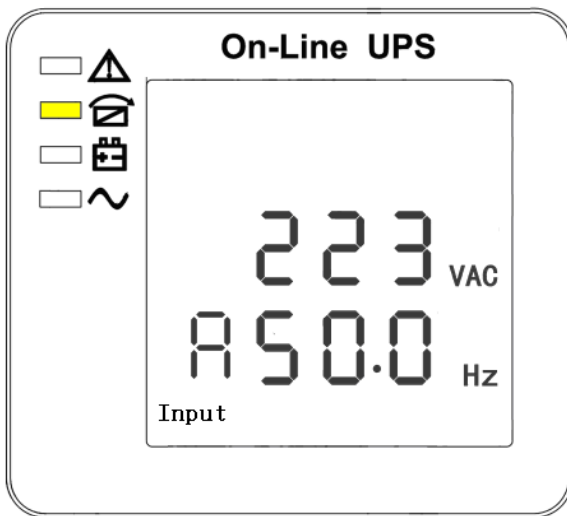

2.Phase A(L1) Input/Frequency

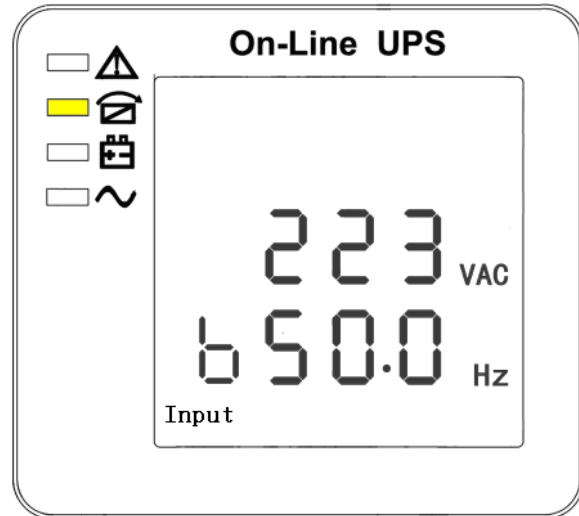

3. Phase B(L2) Input/Frequency

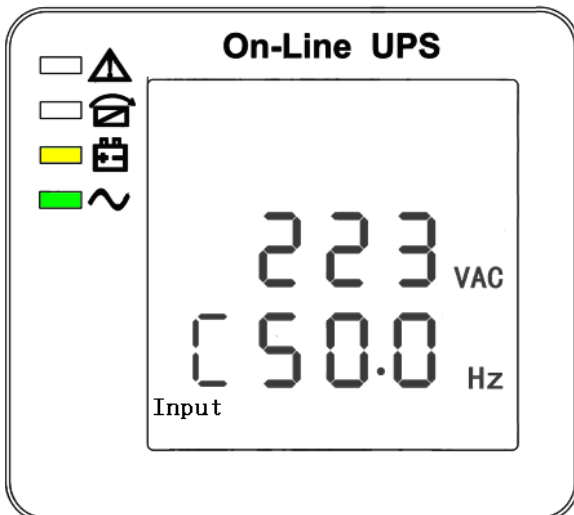

4. Phase C(L3) Input/Frequency

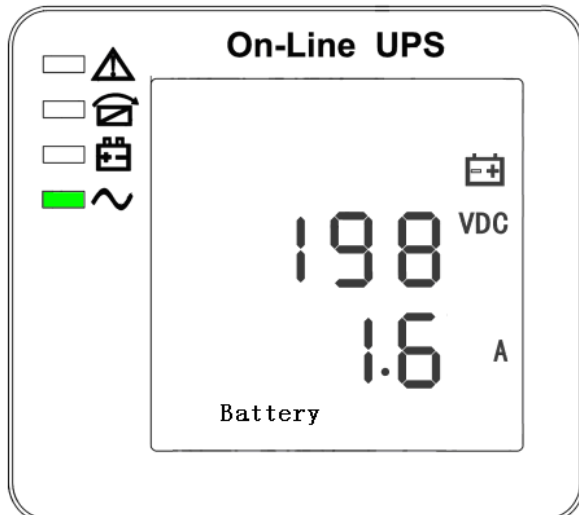

5. Bat +(Positive)

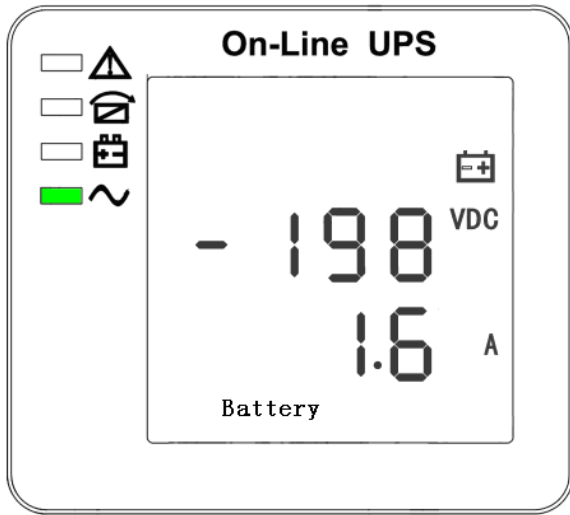

6. Bat -(Negative)

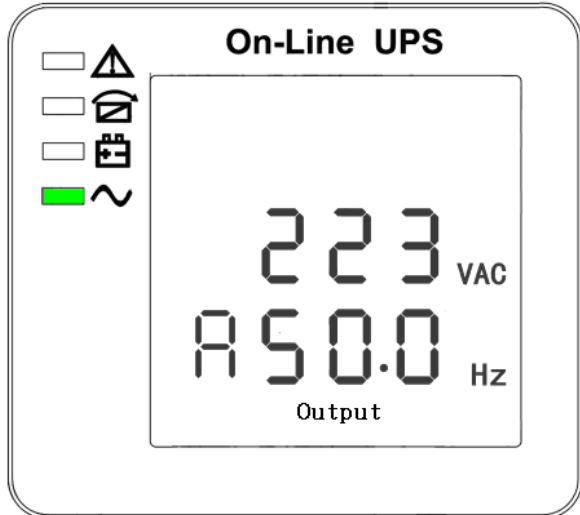

7. Phase A(L1) Output Voltage/Frequency

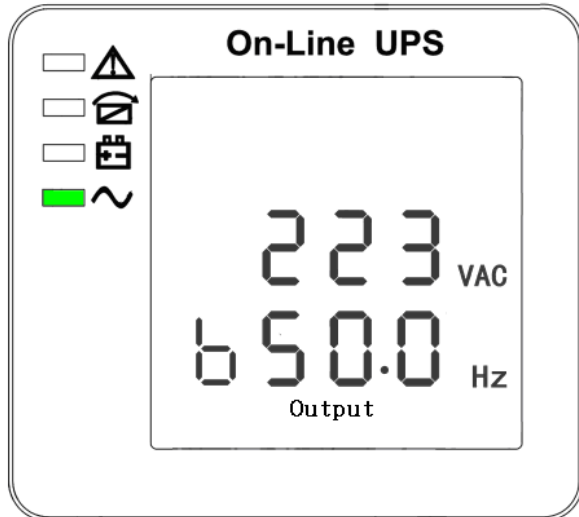

8. Phase B(L2) Output Voltage/Frequency

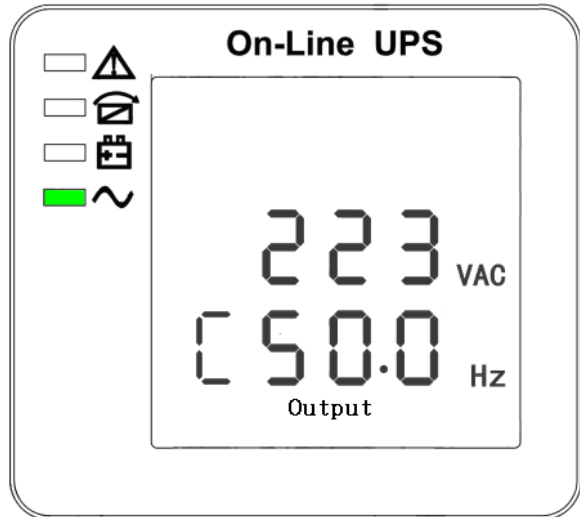

9. Phase C(L3) Output Voltage/Frequency

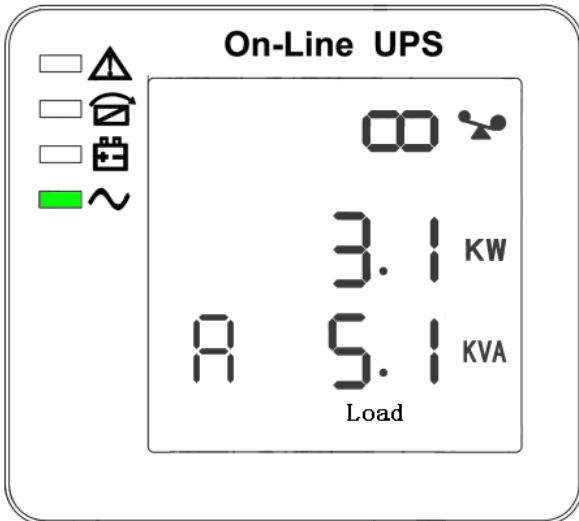

10. Phase A(L1) Load Capacity

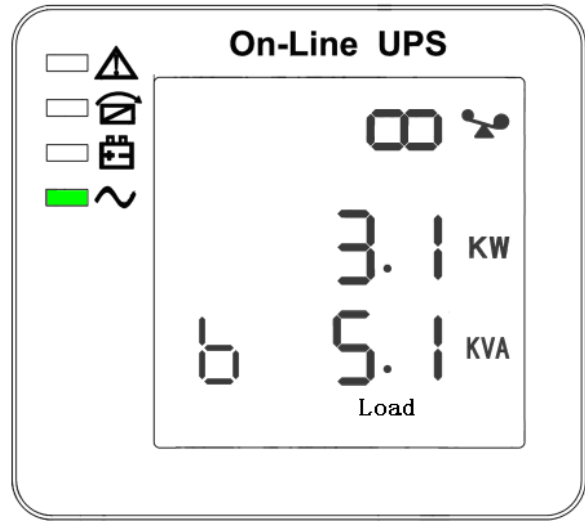

11. Phase B(L2) Load Capacity

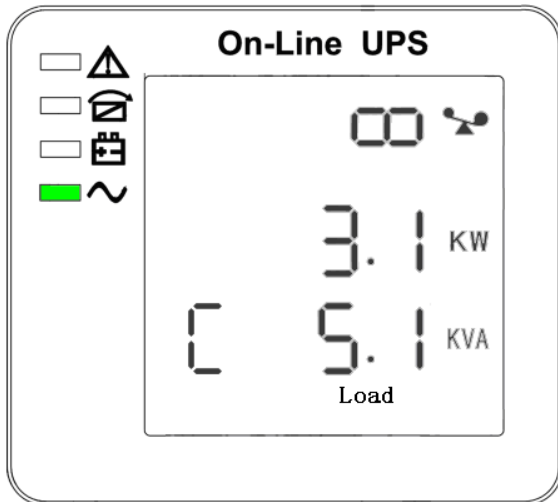

12. Phase C(L3) Load Capacity

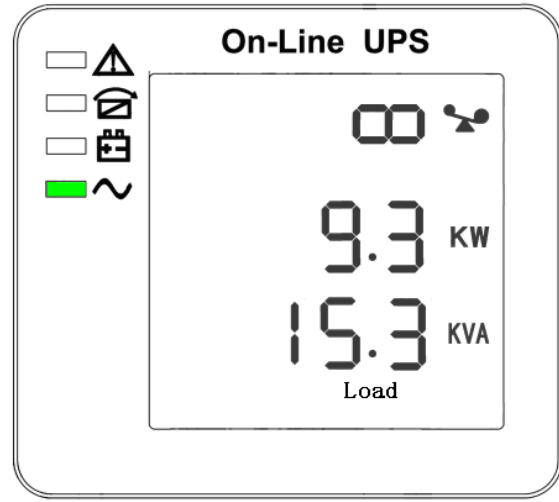

13. Total Load Capacity

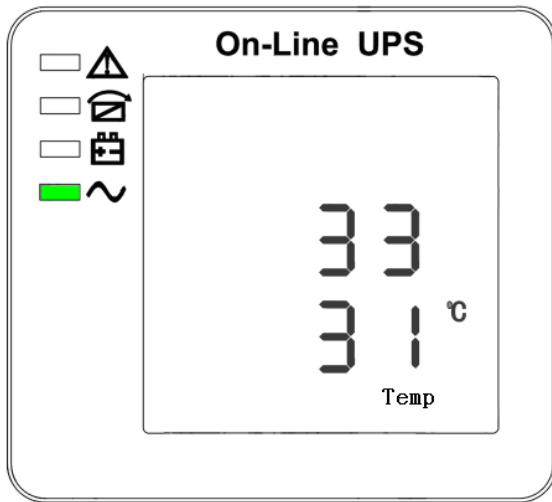

14. Internal temperature and ambient temperature

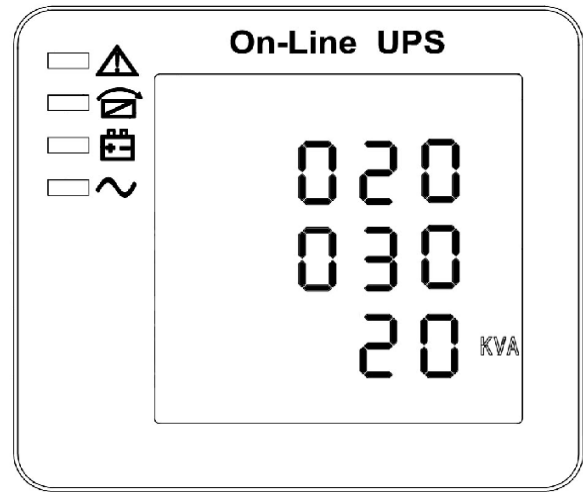

15. Software version & model

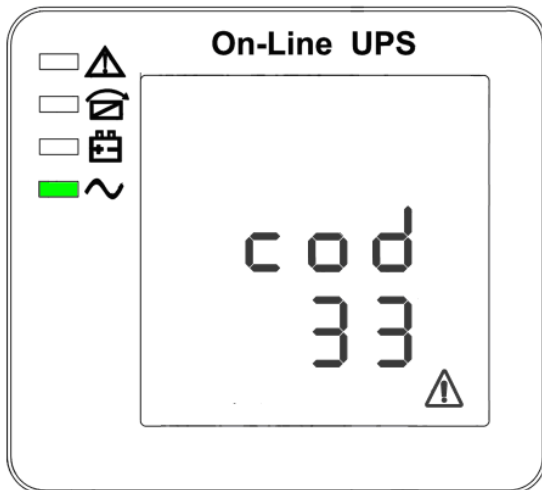

16. Alarm Code

If some of above interfaces have battery charging, it will display the charging information at the same

4.3.3 Monitoring Module Control Panel

Monitoring module control panel is at UPS top. Through this control panel and LED, the operator may monitor all measured data, UPS & battery status, and alarm events.

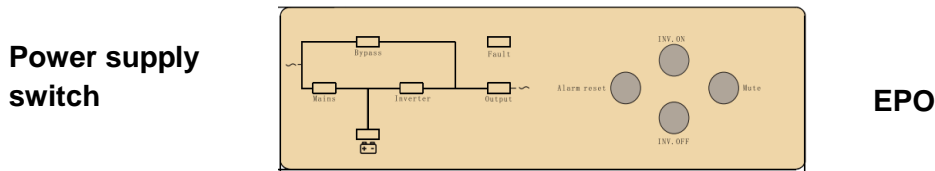

1. Power supply switch: the power supply switch of the monitoring module. After switch it off, the monitoring module can be hot swapped.
2. EPO KEY: Disconnects Power to the Load. Disables rectifier, inverter, static bypass and battery operation
3. MAINS INDICATOR (LED): the status of the AC Input
4. INVERT INDICATOR (LED): the status of the inverter
5. OUTPUT INDICATOR (LED): the status of the output
6. BYPASS INDICATOR (LED): the status of the bypass Input
7. BAT INDICATOR (LED): the status of the battery
8. FAULT INDICATOR (LED): UPS is faulty
9. ALARM RESET: to reset alarm.
10. MUTE: MUTE function of monitoring module, to mute buzzer, The buzzer will be re-started automatically when fault occurs.
11. INVERTER OFF KEY: Disable Inverter Operation
12. INVERTER ON KEY: Enable Inverter Operation



CAUTION!

The LEDs mounted on the mimic flow chart represent the various power paths and current UPS operational status.

Mains indicator

Green	Rectifier in Normal Operation
Flashing Green	Input mains voltage or frequency out of normal range
Off	Input AC Not Available

Battery indicator

Green	Battery Normal, but discharging and powering the load
Flashing Green	Battery End of Discharge pre-warning, Battery abnormal (high or low voltage, Absent or Polarity Reversed), charger abnormal
Off	Battery and Converter Normal, Battery charging.

Bypass indicator

Green	Load on Bypass power
Flashing Green	Bypass not available, out of normal range, Static bypass switch short or broken fault, bypass switch wiring fault, bypass over current
Off	Bypass Normal, load not on bypass

Inverter indicator

Green	Inverter Normal and powering the load
Flashing Green	Inverter failed, Inverter IGBT bridge direct conduct protection, Inverter Thyristor short or broken fault, over load or Parallel Overload, Feedback protection
Off	Inverter not operating

Output indicator

Green	UPS output ON and Normal
Off	UPS output OFF.

Ffault indicator

Off	Normal Operation
Red	UPS fault e.g.

4.4 Display Messages/Troubleshooting

This section lists the event and alarm messages that the UPS might display. The messages are listed in alphabetical order. This section is listed with each alarm message to help you troubleshoot problems .

Module Display messages

Operational Status and Mode(s)

item	Content Displayed	LED			
		alarm	Bps output	Bat. output	Mains output
1	Initialized	Extinguish	Extinguish	Extinguish	Extinguish
2	Standby Mode	Extinguish	Extinguish	X	Extinguish
3	No Output	Extinguish	Extinguish	X	Extinguish
4	Bypass Mode	Extinguish	Light	X	Extinguish
5	Utility Mode	Extinguish	Extinguish	X	Light
6	Battery Mode	Extinguish	Extinguish	Light	Extinguish
7	Battery Self-diagnostics	Extinguish	Extinguish	Light	Extinguish
8	Inverter is starting up	Extinguish	X	X	Extinguish
9	ECO Mode	Extinguish	X	X	X
10	EPO Mode	Light	Extinguish	X	Extinguish
11	Maintenance Bypass Mode	Extinguish	Extinguish	Extinguish	Extinguish
12	Fault Mode	Light	X	X	X

Note : "X" shows that it will determined by other conditions.

Module Alarm Information

Event log	UPS Alarm Warning	Buzzer	LED
1	Rectifier Fault	Beep continuously	Fault LED lit
2	Inverter fault(Including Inverter bridge is shorted)	Beep continuously	Fault LED lit
3	Inverter Thyristor short	Beep continuously	Fault LED lit
4	Inverter Thyristor broken	Beep continuously	Fault LED lit
5	Bypass Thyristor short	Beep continuously	Fault LED lit
6	Bypass Thyristor broken	Beep continuously	Fault LED lit
7	Fuse broken	Beep continuously	Fault LED lit
8	Parallel relay fault	Beep continuously	Fault LED lit
9	Fan fault	Beep continuously	Fault LED lit
10	reserve	Beep continuously	Fault LED lit
11	Auxiliary power fault	Beep continuously	Fault LED lit
12	Initializtion fault	Beep continuously	Fault LED lit
13	P-Battery Charger fault	Beep continuously	Fault LED lit
14	N-Battery Charger fault	Beep continuously	Fault LED lit
15	DC Bus over voltage	Beep continuously	Fault LED lit
16	DC Bus below voltage	Beep continuously	Fault LED lit
17	DC bus unbalance	Beep continuously	Fault LED lit
18	Soft start failed	Beep continuously	Fault LED lit
19	Rectifier Over Temperature	Twice per second	Fault LED lit
20	Inverter Over temperature	Twice per second	Fault LED lit
21	reserve	Twice per second	Fault LED lit
22	Battery reverse	Twice per second	Fault LED lit
23	Cable connection error	Twice per second	Fault LED lit
24	CAN comm. Fault	Twice per second	Fault LED lit
25	Parallel load sharing fault	Twice per second	Fault LED lit
26	Battery over voltage	Once per second	Fault LED blinking
27	Mains Site Wiring Fault	Once per second	Fault LED blinking
28	Bypass Site Wiring Fault	Once per second	Fault LED blinking
29	Output Short-circuit	Once per second	Fault LED blinking
30	Rectifier over current	Once per second	Fault LED blinking
31	Bypass over current	Once per second	BPS LED blinking
32	Overload	Once per second	INV or BPS LED blinking
33	No battery	Once per second	Battery LED blinking
34	Battery under voltage	Once per second	Battery LED blinking
35	Battery low pre-warning	Once per second	Battery LED blinking
36	Internal Communication Error	Once per 2 seconds	Fault LED blinking
37	DC component over limit.	Once per 2 seconds	INV LED blinking
38	Parallel Overload	Once per 2 seconds	INV LED blinking

39	Mains volt. Abnormal	Once per 2 seconds	Battery LED lit
40	Mains freq. abnormal	Once per 2 seconds	Battery LED lit
41	Bypass Not Available		BPS LED blinking
42	Bypass unable to trace		BPS LED blinking
43	Inverter on invalid		
44	Module screws unlocked		

Cabinet Display messages

Events:

No.	Display message	Meaning
3	Initializing	The DSP and MCU are in Initializing.
4	Standby	
5	Non-Output	The UPS does not provide power to the load equipment.
6	On Bypass	Inverter output is turned off and the load connected at the inverter output receives power from utility line via STS.
7	On Line	Inverter output power is the primary energy source to load
8	EPO Activated	Emergency Power Off Switch has been activated.
9	Automatic Self Test	The UPS has started pre-programmed battery test.
10	Inverter in soft starting	The inverter is in soft-starting
11	System Fault Detected	The system has detected an internal error
12	MBS status	status of maintenance bypass
13	EPO status	status of EPO(emergency power off)
14	Int. Input Switch closed	The internal input breaker is closed manually.
15	Int. Input Switch opened	The internal input breaker is opened manually.
16	Rectifier Deactivated	The rectifier has been deactivated.
17	Rectifier Activated	The rectifier has been activated.
18	Rectifier Current Limit	When the input voltage is at 208V~305V, the output of the UPS will not be interrupted, but it will be at current limit, for example, to reduce charge current. When the load connected exceeds its limit, the warning shall occur.
19	Battery charge deactivated	The charger has been deactivated.
20	Positive Battery Boost Charging	The Positive battery is in boost charge, which is Constant voltage boost charge mode or constant current boost charge mode.
21	Positive Battery Float Charging	The Positive battery is in float charge.
22	Negative Battery Boost Charging	The Negative battery is in boost charge.

23	Negative Battery Float Charging	The Negative battery is in float charge.
24	Int. bypass Switch Opened	The internal bypass breaker is opened manually
25	Int. bypass Switch Closed	The internal bypass breaker is closed manually
26	Int. output Switch Opened	The internal output breaker is opened manually
27	Int. output Switch Closed	The internal output breaker is closed manually
28	Ext. bypass Switch Opened	The external bypass breaker(parallel system) is opened
29	Ext. bypass Switch Closed	The external bypass breaker(parallel system) is closed
30	Ext. output Switch Opened	The external output breaker(parallel system) is opened
31	Ext. output Switch Closed	The external output breaker(parallel system) is closed
32	Coming to Interval transfer	Allows transfer to bypass or inverter with 3/4 cycle break. Use of this command will drop load.
33	Coming to over load due to inverter off	When the inverter is turned off manually, the load will exceed the power capacity.
34	Coming to Interval transfer due to inverter off	When the inverter is turned off manually, the load will exceed the power capacity.
35	Inverter invalid due to over load	The load exceeds the capability of the single or parallel modules.
36	Inverter Master	It indicates the Master Inverter.
37	Transfer Times-out	Latched load transfer to bypass as a result of too many successive transfers within the current hour. Automatic reset attempt within the next hour.
38	UPS In shutdown Due To Overload.	The load exceeded the power capacity. The UPS has been shutdown
39	UPS In Bypass Due To Overload.	The load exceeded the power capacity. The UPS has switched to Bypass Mode.
40	Parallel in Bypass	The parallel system has switched to bypass mode
41	LBS Activated	LBS has been activated.
42	Lightning Protection	Lightning protector has been activated.
43	Battery low to UPS OFF	battery voltage lower than protection point
44	UPS timing on	UPS on at certain time
45	UPS timing OFF	UPS off at certain time
46	timing self-test start	start to self-test at certain time
47	Stop self-test	self-test stops
48	manual OFF	turn off UPS manually
49	remote OFF	turn off UPS remotely
50	module connected	module is connected
51	module removed	module is removed

Cabinet Alarm Information

No.	Display message	Meaning
52	Rectifier Fault	Rectifier detected faulty. Rectifier and inverter and charger shut down.
53	Rectifier Over Temperature	The temperature of heat sink is too high to keep the rectifier running. Charger and inverter shut down.
54	Inverter Over temperature	The temperature of the inverter heat sink is too high to keep inverter running.
55	Rectifier over-current	Rectifier failure due to over-current
56	Input thyristor failure	Failure of input thyristor
57	Battery discharge thyristor failure	Failure of battery discharge thyristor
58	Battery charge thyristor failure	Failure of battery charge thyristor
59	Fan fault	At least one of the cooling fans fails. Rectifier and inverter and charger shut down.
60	DC Bus over-voltage	Rectifier, inverter and battery converter are shutdown due to high DC bus voltage.
61	DC Bus under-voltage	Rectifier, inverter and battery converter are shutdown due to low DC bus voltage.
62	DC bus unbalance	If the difference between positive DC bus and negative DC bus exceeds 30V, this warning shall occur.
63	Soft start fault	Rectifier could not be started due to low DC bus voltage
64	Input Neutral line missing	If Input Neutral line is missing or disconnected while the UPS is in operation, the UPS will generate Neutral line failure alarm and go into Battery mode.
65	Battery Reverse	The polarity of the battery is reversed.
66	No Battery	Battery is disconnected
67	Positive Battery Charger fault	The positive battery Charger is fault. The charger will be shut down.
68	Negative battery charger fault	The negative battery charger is fault. The charger will be shut down.
69	Battery under-voltage	The battery voltage is too low and the charger has been deactivated.
70	Battery over-voltage	The battery voltage is too high and the charger has been deactivated.
71	Battery under-voltage pre-warning	The UPS is in battery operation and the battery voltage is low. Note: Runtime is limited in duration.
72	Mains freq. abnormal	Mains frequency is out of limit range and results in rectifier shutdown.
73	Mains volt. Abnormal	Mains Voltage exceeds the upper or lower limit and results in rectifier shutdown.

74	Inverter fault	When inverter has been turned on for a certain time, but the output voltage of the inverter is still out of the range of Rating voltage +12.5% and -25%, inverter fault will occur, and the inverter will be shut down and the UPS will transfer to bypass. This fault cannot be cleared until this unit is completely powered off.
75	Inverter IGBT bridge direct conduct protection	If the two IGBTs in the same bridge of inverter are on simultaneously, inverter should be shut down
76	Inverter Thyristor short fault	SCR at the inverter side is short-circuited
77	Inverter Thyristor broken fault	SCR at the inverter side is open-circuited
78	Bypass Thyristor short fault	SCR at the bypass side is short-circuited
79	Bypass Thyristor broken fault	SCR at the bypass side is open-circuited
80	CAN comm. Fault	The CAN bus communication fails
81	Parallel system load sharing fault	If any unit in a parallel system has an unbalance load share that exceeds 30%, this warning will occur.
82	Bypass Site Wiring Fault	Wrong phase rotation on the bypass side.
83	System Not Synchronized To Bypass.	System cannot synchronize to bypass. Bypass Mode may not be available.
84	Bypass unable to trace	Bypass is unable to trace
85	Bypass Not Available	The frequency or voltage is out of acceptable range for bypass. This message occurs when the UPS is online, and indicates that the bypass mode may not be available if required.
86	IGBT over current	IGBT current is over limit.
87	Parallel cable connection error	If a unit is set as parallel mode, but parallel cable is not connected correctly, this warning will occur
88	Parallel relay fault	Relay of parallel circuit must be turned on when the system are in parallel and the inverter is on. If the relay of parallel circuit cannot be turned on correctly, this unit should be shut down (include inverter and bypass). This fault cannot be cleared until this unit is completely powered off.
89	LBS Not SYNC.	Two parallel systems are not in synchronization.
90	initialization fault	When the procedure of initialization is wrong, this warning will occur.
91	Inverter is invalid	The inverter on button has been activated.
92	Overload	The load exceeds the system power capacity.
93	Parallel Overload	The UPS parallel system is confirmed to be overloaded according to the set number.
94	DC component over limitation	If the DC component of the UPS output rating power is larger than the limitation, this warning should occur
95	Bypass over current	When the bypass current exceeds the limitation, this alarm will occur.

96	Feedback protection	This UPS is fitted with a voltage free contact closure signal for use with an external automatic disconnect device (by others) to protect against back-feeding voltage into the incoming bypass supply
97	Ext. Fire Alarm	External fire detector has been activated.
98	Ext. Smoke Alarm	External smoke detector has been activated.
99	battery damaged	battery has been damaged, this warning shall occur.
100	battery over-temperature	battery over-temperature, this warning shall occur.
101	model set wrong	Model setting of the UPS is incorrect.

4.5 Options

Network Management Card with Environmental Monitoring



CAUTION!

For network management configuration and use, refer to the separate user manual - Network Management Card with Environmental Monitor - shipped with the CARD.

Network Management Card replacement

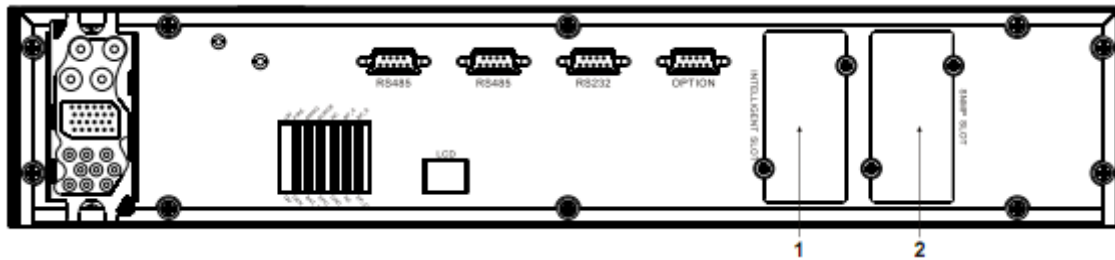

1: Intelligent Network Port

2: SNMP port

PM SERIES

SNMP card: internal SNMP / external SNMP optional

- Loosen the 2 torque screws (on each side of the card).
- Carefully pull out the card. Reverse the procedure for re-installation

The slot called SNMP supports the MEGAtec protocol. We advise that NetAgent II-3 port is also a tool to remotely monitor and manage any UPS system

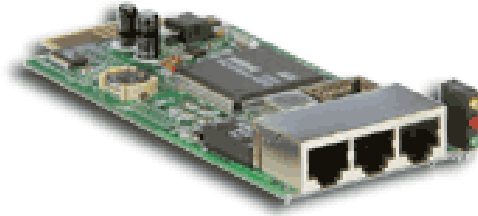

the overview of the SNMP card

NetAgent II-3Ports supports the Modem Dial-in(PPP) function to enable the remote control via the internet when the network is unavailable .

In addition to the features of a standard NetAgent Mini, NetAgent II has the option to add NetFeeler Lite to detect temperature, humidity, smoke and security sensors. Thus, making NetAgent II a versatile management tool. NetAgent II also supports multiple languages and is setup for web-based auto language detection .

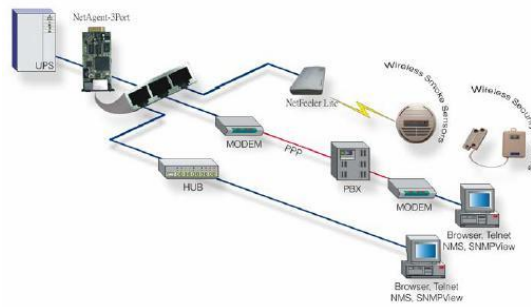

Typical topology of the UPS Network Management

Relay card

A 10-pin terminal is supported to offer the signals of Bypass, Utility Failure, Inverter On, Battery Low, UPS fault, UPS Alarm, and UPS Shutdown.

The relay communication card contains six dry contact outputs and one dry input. The inputs and outputs are factory programmed according to functions listed in the table

Table:Relay Contacts (communication card)

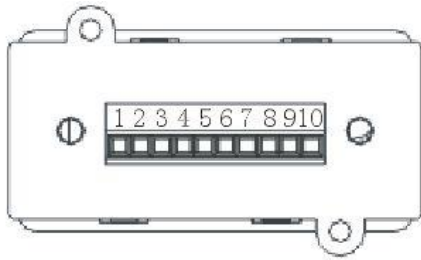

Port		Function
1	Output	Utility Failure
2		/
3		Battery Low
4		On Bypass
5		UPS Fault
6		Inverter On
7		UPS Alarm
8	COM	
9	Input	ON
10		OFF



CAUTION!

The output contacts numbers for a second relay board installed will be 1 to 7.

Contacts are NO (normally open) type.



available at no charge in any of Overview of the relay card

Appendix 1 Specifications

Model		1.4M Rack Cabinet	2M Rack Cabinet	
Capacity	UPS Cabinet	10~100KVA/9~90KW	10~200KVA/9~180KW	
	UPS Module	10KVA/9KW, 15KVA/13.5KW, 20KVA/18KW		
Input	Phase	3 Phase 4 Wires and Ground		
	Rated Voltage	380/400/415Vac		
	Voltage Range	208~478Vac		
	Frequency Range	40Hz-70Hz		
	Power Factor	≥0.99		
	Current THDi	≤3%(100% nonlinear load)		
	Bypass Voltage Range	Max.voltage: +15%(optional +5%,+10%,+25%) Min. voltage: -45% (optional -20%,-30%) Frequency protection range: ±10%		
	Generator Input	Support		
Output	Phase	3 Phase 4 Wires and Ground		
	Rated Voltage	380/400/415Vac		
	Power Factor	0.9		
	Voltage Regulation	±2%		
	Frequency	Utility Mode	±1%,±2%,±4%,±5%,±10% of the rated frequency(optional)	
		Battery Mode	(50/60±0.2%)Hz	
	Crest Factor	3:1		
	THD	≤2% with linear load ≤5% with non linear load		
	Waveform	Pure Sinewave		
Efficiency		≥92% at normal mode		
Battery	Voltage	±192V\±204V\±216V\±228V\±240V DC; battery quantity(optional)		
	Charging Current	UPS Cabinet	30A Max.	
		UPS Module	6A Max.	
		charge current can be set according to battery capacity installed		
Transfer Time		Utility to Battery : 0ms; Utility to bypass: 0ms		
Protection	Overload	AC Mode	Load≤110%: last 60min,≤125%: last 10min,≤150%: last 1min,≥150% shut down UPS immediately.	
		Bat. Mode	Load≤110%: last 10min≤125%: last 1min,≤150%: last 1S,≥150% shut down UPS immediately.	
		Bypass Mode	Breaker (10KVA: 20A / 15KVA: 32A / 20KVA:40A)	
	Short Circuit	Hold Whole System		
	Overheat	Line Mode: Switch to Bypass; Backup Mode: Shut down UPS immediately		
	Battery Low	Alarm and Switch off		
	Self-diagnostics	Upon Power On and Software Control		

PM SERIES

	EPO(optional)		Shut down UPS immediately		
	Battery		Advanced Battery Management		
	Noise Suppression		Complies with EN62040-2		
Alarms	Audible & Visual		Line Failure, Battery Low, Overload, System Fault		
Display	Status LED & LCD		Line Mode, Eco Mode, Bypass Mode, Battery Low, Battery Bad, Overload & UPS Fault		
	Reading On the LCD		Input Voltage, Input Frequency, Output Voltage, Output Frequency, Load Percentage, Battery Voltage & Inner Temperature		
Communication Interface			RS232, RS485, Intelligent slot x 2, Dry Contact		
Environment	Operating Temperature		0°C ~ 40°C		
	Storage Temperature		-25°C ~ 55°C		
	Humidity		0~95% non condensing		
	Altitude		< 1500m		
Other	Unit Dimensions(W*H*D)	UPS Cabinet	600x840x1400mm	600x1100x2000mm	
		UPS Module	443x131x580mm		
	Weight (Kg)	UPS Cabinet	170	270	
		UPS Module	10KVA:26, 15KVA:30, 20KVA:31		
Safety Conformance			CE,EN/IEC 62040-2,EN/IEC 62040-1-1		

Appendix 2 UPS message table

1. The Inner Code is applied to this Series. The following format block is Inner Code display on LCD:

AAAA-AAAA BBBB-BBBB EEFF
 CCCC-CCCC DDDD-DDDD

2. The part of Inner Code means

AAAA-AAAA (Rectifier State) :

Axxx-xxxx

							8	9	A	B	C	D	E	F	Int. Input Switch closed
		4	5	6	7						C	D	E	F	Rectifier Activated
	2	3		6	7				A	B			E	F	Emergency Power off
1		3		5	7		9			B		D		F	Rectifier current Limit

xAxx-xxxx

							8	9	A	B	C	D	E	F	Input Power work on
		4	5	6	7						C	D	E	F	Power by Input
	2	3		6	7				A	B			E	F	Battery Test
1		3		5	7		9			B		D		F	Battery Charge

xxAx-xxxx

							8	9	A	B	C	D	E	F	P-Battery Boost Charge
		4	5	6	7						C	D	E	F	N-Battery Boost Charge
	2	3		6	7				A	B			E	F	
1		3		5	7		9			B		D		F	

xxxA-xxxx

							8	9	A	B	C	D	E	F	
		4	5	6	7						C	D	E	F	
	2	3		6	7				A	B			E	F	
1		3		5	7		9			B		D		F	

xxxx-Axxx

							8	9	A	B	C	D	E	F	communication connected
		4	5	6	7						C	D	E	F	
	2	3		6	7				A	B			E	F	
1		3		5	7		9			B		D		F	

xxxx-xAxx

							8	9	A	B	C	D	E	F	
		4	5	6	7						C	D	E	F	
	2	3		6	7				A	B			E	F	
1		3		5	7		9			B		D		F	

xxxx-xxAx

							8	9	A	B	C	D	E	F	
		4	5	6	7						C	D	E	F	
	2	3		6	7				A	B			E	F	
1		3		5	7		9			B		D		F	

xxxx-xxxA

							8	9	A	B	C	D	E	F	
		4	5	6	7						C	D	E	F	
	2	3		6	7				A	B			E	F	
1		3		5	7		9			B		D		F	

BBBB-BBBB (Inverter State) :

PM SERIES

Bxxx-xxxx

							8	9	A	B	C	D	E	F	Int. bypass Switch Closed
		4	5	6	7						C	D	E	F	Int. output Switch Closed
	2	3		6	7				A	B			E	F	Manu-Bypass Switch Closed
1		3		5	7		9			B		D		F	Ext. bypass Switch Closed

xBxx-xxxx

							8	9	A	B	C	D	E	F	Ext. output Switch Closed
		4	5	6	7						C	D	E	F	00: Shut Down, 01: Inv starting, 10: Inv work on ,but No Output 11: Normal Output
	2	3		6	7				A	B	C		E	F	
1		3		5	7		9			B		D		F	

xxBx-xxxx

							8	9	A	B	C	D	E	F	Output by Bypass
		4	5	6	7						C	D	E	F	Cue: Interval Transfer
	2	3		6	7				A	B			E	F	Cue: turn-off, System will be broken
1		3		5	7		9			B		D		F	Cue: turn-off, Parallel will be overloaded

xxxB-xxxx

							8	9	A	B	C	D	E	F	Emergency Power off
		4	5	6	7						C	D	E	F	INV.invalid due to Overload
	2	3		6	7				A	B			E	F	Change Master
1		3		5	7		9			B		D		F	Transfer Times-out

xxxx-Bxxx

							8	9	A	B	C	D	E	F	Shutdown Due To Overload
		4	5	6	7						C	D	E	F	On Bypass Due To Overload
	2	3		6	7				A	B			E	F	Parallel in Bypass
1		3		5	7		9			B		D		F	LBS Activated

xxxx-xBxx

							8	9	A	B	C	D	E	F	INV standby
		4	5	6	7						C	D	E	F	
	2	3		6	7				A	B			E	F	
1		3		5	7		9			B		D		F	

xxxx-xxBx

							8	9	A	B	C	D	E	F	Shutdown Due To Overload
		4	5	6	7						C	D	E	F	On Bypass Due To Overload
	2	3		6	7				A	B			E	F	Parallel in Bypass
1		3		5	7		9			B		D		F	LBS Activated

xxxx-xxxB

							8	9	A	B	C	D	E	F	INV standby
		4	5	6	7						C	D	E	F	
	2	3		6	7				A	B			E	F	
1		3		5	7		9			B		D		F	

CCCC-CCCC (Rectifier Alarm) :

Cxxx-xxxx

						8	9	A	B	C	D	E	F	Rectifier fault	
			4	5	6	7				C	D	E	F	Rectifier over temperature	
	2	3			6	7			A	B			E	F	Inverter over temperature
1		3		5		7		9		B		D		F	Rectifier over current

xCxx-xxxx

						8	9	A	B	C	D	E	F	Auxiliary power 1 fault	
			4	5	6	7				C	D	E	F	Auxiliary power 2 fault	
	2	3			6	7			A	B			E	F	Input Thyristor failed
1		3		5		7		9		B		D		F	Discharge Thyristor failed

xxCx-xxxx

						8	9	A	B	C	D	E	F	Charge Thyristor failed	
			4	5	6	7				C	D	E	F	Fan fault	
	2	3			6	7			A	B			E	F	Fan Power fault
1		3		5		7		9		B		D		F	DC Bus over voltage

xxxC-xxxx

						8	9	A	B	C	D	E	F	DC Bus below voltage	
			4	5	6	7				C	D	E	F	DC bus unbalance	
	2	3			6	7			A	B			E	F	Mains Site Wiring Fault
1		3		5		7		9		B		D		F	Soft start failed

xxxx-Cxxx

						8	9	A	B	C	D	E	F	Input Neutral line missing	
			4	5	6	7				C	D	E	F	Battery reverse	
	2	3			6	7			A	B			E	F	No battery
1		3		5		7		9		B		D		F	P-Battery Charger fault

xxxx-xCxx

						8	9	A	B	C	D	E	F	N-Battery Charger fault	
			4	5	6	7				C	D	E	F	Battery under voltage	
	2	3			6	7			A	B			E	F	Battery over voltage
1		3		5		7		9		B		D		F	Battery low pre-warning

xxxx-xxCx

						8	9	A	B	C	D	E	F	Mains freq. abnormal	
			4	5	6	7				C	D	E	F	Mains volt. Abnormal	
	2	3			6	7			A	B			E	F	
1		3		5		7		9		B		D		F	

xxxx-xxxC

						8	9	A	B	C	D	E	F		
			4	5	6	7				C	D	E	F		
	2	3			6	7			A	B			E	F	
1		3		5		7		9		B		D		F	

DDDD-DDDD (Inverter Alarm) :

Dxxx-xxxx

						8	9	A	B	C	D	E	F	Inverter fault
		4	5	6	7					C	D	E	F	Inv. IGBT bridge shorted
	2	3		6	7			A	B			E	F	Inverter Thyristor short
1		3		5	7		9		B		D		F	Inverter Thyristor broken

xDxx-xxxx

						8	9	A	B	C	D	E	F	Bypass Thyristor short
		4	5	6	7					C	D	E	F	Bypass Thyristor broken
	2	3		6	7			A	B			E	F	CAN comm. Fault
1		3		5	7		9		B		D		F	Parallel load sharing fault

xxDx-xxxx

						8	9	A	B	C	D	E	F	Bypass Site Wiring Fault
		4	5	6	7					C	D	E	F	System not Sync. to Bypass
	2	3		6	7			A	B			E	F	Bypass unable to trace
1		3		5	7		9		B		D		F	Bypass Not Available

xxxD-xxxx

						8	9	A	B	C	D	E	F	IGBT over current
		4	5	6	7					C	D	E	F	Fuse broken
	2	3		6	7			A	B			E	F	Cable connection error
1		3		5	7		9		B		D		F	Parallel relay fault

xxxx-Dxxx

						8	9	A	B	C	D	E	F	LBS Not SYNC.
		4	5	6	7					C	D	E	F	Initialization fault
	2	3		6	7			A	B			E	F	Inverter on invalid
1		3		5	7		9		B		D		F	Overload

xxxx-xDxx

						8	9	A	B	C	D	E	F	Parallel Overload
		4	5	6	7					C	D	E	F	DC component over limit.
	2	3		6	7			A	B			E	F	Bypass over current
1		3		5	7		9		B		D		F	Feedback protection

xxxx-xxDx

						8	9	A	B	C	D	E	F	BUS voltage abnormal
		4	5	6	7					C	D	E	F	
	2	3		6	7			A	B			E	F	
1		3		5	7		9		B		D		F	

xxxx-xxxD

						8	9	A	B	C	D	E	F	
		4	5	6	7					C	D	E	F	
	2	3		6	7			A	B			E	F	
1		3		5	7		9		B		D		F	

EE (Inside Monitor) :

Ex

						8	9	A	B	C	D	E	F	generator Connect	
			4	5	6	7				C	D	E	F	Shutdown Due To Batt. Low	
	2	3			6	7		A	B			E	F	Time to turn on	
1		3		5		7		9		B		D		F	Time to turn off

xE

							8	9	A	B	C	D	E	F	timing self test start
			4	5	6	7					C	D	E	F	Surge protection active signal, from monitoring board IO
	2	3			6	7			A	B			E	F	battery monitoring system
1		3		5		7		9		B		D		F	system unregistered

FF (Monitoring)

Fx

							8	9	A	B	C	D	E	F	Battery Fault (from battery monitoring)
			4	5	6	7					C	D	E	F	Battery over temperature (from battery monitoring)
	2	3			6	7			A	B	C		E	F	Battery over voltage (from battery monitoring)
1		3		5		7		9		B		D		F	Battery under voltage (from battery monitoring)

xF

							8	9	A	B	C	D	E	F	External Fire Alarm (from monitoring board IO)
			4	5	6	7					C	D	E	F	External Smoke Alarm (from monitoring board IO)
	2	3			6	7			A	B			E	F	UPS model wrong
1		3		5		7		9		B		D		F	time up for suggested maintenance

Appendix 3 Problems and Solution

In case the UPS can not work normally, it might be wrong in installation, wiring or operation. Please check these aspects first. If all these aspects are checked without any problem, please consult with local agent right away and provide below informations.

1. Product model name and serial number, which can be found in LCD display.
2. Try to describe the fault with more details, such as LCD display info, LED lights status, etc.

Read the user manual carefully, it can help a lot for using this UPS in the right way. Some FAQ (frequently asked questions) may help you to troubleshoot your problem easily.

No.	Problem	Possible reason	Solution
1	LCD not display	The network cable is not fixed properly or the telephone line of the front door is not fixed properly.	Connect the network cable and telephone cable properly.
2	LCD Blue screen	LCD is interfered	Take out the cable and insert back properly
3	Utility is connected but the UPS can not be powered ON.	Input power supply is not connected; Input voltage low; The input switch of the module is not switched on .	measure if the UPS input voltage/frequency are within the window. Check if all modules input are switched on
4	Utility normal but Utility LED does not light on, and the UPS operates at battery mode	The input breakers of the Modules are not switched on; input cable is not well connected	Switch on the input breaker; Make sure the input cable is well connected.
5	The UPS does not indicate any failure, but output do not have voltage	Output cable does not well connected	Make sure the output cable is well connected.
6	The UPS module can not transfer to bypass or inverter	Module does not well inserted; The left coronal screw is not tight. Output breaker do not switch on	Pull out the module and insert again; Tighten the screw; Switch on the output breaker.

7	The UPS module fault LED remains ON	The module is already damaged	Take out this module, replace with a new module.
8	Utility LED is flashing	Utility voltage exceeds UPS input range.	If the UPS operates at battery mode, please pay attention to the remaining backup time needed for your system.
9	Battery LED is flashing but no charge voltage and current	Battery breaker does not switch on, or batteries are damaged, or battery is reversely connected. battery number and capacity are not set correctly.	Switch on the battery breaker. If batteries are damaged, need to replace whole group batteries, Connect the battery cables correctly; Go to LCD setting of the battery number and capacity, set the correct data.
10	Buzzer beeps every 0.5 seconds and LCD display "output overload"	Overload	remove some load
11	Buzzer long beeps, LCD display "output short circuit"	The UPS output is in short circuit	Make sure the load is not in short circuit, then restart the UPS.
12	The LED of the Module with RED light	The module is not inserted properly.	Pull out the module and insert properly.
13	The UPS only works on bypass mode	The UPS is set to ECO mode, or the transfer times to bypass mode are limited.	Set the UPS working mode to Single Module type(non-parallel) or to reset the times of transferring to bypass or re-start the UPS
14	Can not Black start	Battery switch is not properly closed ; Battery fuse is not open ; Or Battery low	Close the battery switch ; Change the fuse ; Recharge the battery
15	Buzzer beeps continuously and LCD indicates Rectifier fault or output fault	UPS is out of order	Consult with your local agent for repair

Appendix 4 RS232 communication port definition

Definition of Male port:

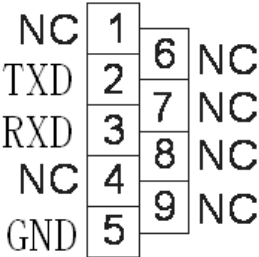

Connection between PC RS232 port and UPS RS232 port

PC RS232 port	UPS RS232 port	
Pin 2	Pin 2	UPS send,PC receive
Pin 3	Pin 3	PC send,UPS receive
Pin 5	Pin 5	ground

Available function of RS232

- Monitor UPS power status.
- Monitor UPS alarm info.
- Monitor UPS running parameters.
- Timing off/on setting.

RS-232 communication data format

Baud rate ----- 2400bps

Byte length ----- 8bit

End bit ----- 1bit

Parity check -----NO

5 GUARANTEE

5.1 Terms of Guarantee

- Our products are under a two-year guarantee starting from the date of delivery against malfunctions resulting from production, material and workmanship faults. Malfunctions due to such type of faults will be removed without claiming any price of workmanship or spare parts to be replaced.
- Whether aforementioned malfunctions originate from usage faults or not are determined with a report to be issued by service stations, if there exists no service stations, by one of seller, dealer, agency, representative, importer or manufacturer or producer of those products respectively.
- Repair time of defective products is twenty business days at most. This period starts from the date when products are delivered to one of seller, dealer, agency, representative, importer or one of manufacturer or producer. Provided that products break down within the period of guarantee, the time passing during the repair process is added to the guarantee time. Provided that faults of products cannot be removed within ten business days, manufacturer-producer or importer is obliged to assign another product having similar features for the use of consumers until the faulty product has been repaired.
- Even though consumers exercise their repair rights, they can claim free replacement of products, refund or price discount at the rate of fault in the events;
 - That, besides, the product, as of the date when the product is delivered to the consumer, breaks down four times a year or six times within the guarantee period to be determined by the manufacturer-producer and/or importer at least, on the condition of being in guarantee period, such malfunctions perpetuate passing over;
 - That maximum time required for the repair of products is exceeded;
 - That repair of the malfunction is determined as impossible through a report to be issued by service station, if there exists no service station, one of seller, dealer, agency, representative, importer or manufacturer or producer of the company respectively.
- The consumer is, on demand, obliged to submit guarantee certificate in terms of repairs or replacements within the scope of guarantee.
- It is essential that you definitely perform damage control over external packaging before receiving the products to be sent through freight. In the event of any damage, delivery person must be made to prepare a “damage determination record”. (For example; during the delivery process, the product has been checked and seen that is damaged.)

- After the damage determination record has been issued, we request you to inform the MAKELSAN head office of the case. Products to be received from freight by signature means that products have been received completely and without no damage.
- Repairs of plug-and-play products in the places where no service point is around are performed in the factory of MAKELSAN or the nearest service point according to the direction to be made by the MAKELSAN head office. Defective product is delivered by hand to the nearest service point or to the contracted freight company in its original packaging to be sent to the factory of MAKELSAN according to the direction to be made by the MAKELSAN head office. For malfunctions in the scope of guarantee, shipment fees are under the responsibility of MAKELSAN on the condition that products are delivered to the contracted freight company.
- The device must be sent as packed in its original packaging as long as it is not desired by the service. Original packaging of devices should be preserved in order to use them for shipment of devices in terms of repairs to occur. Otherwise, no responsibility is assumed with regards to any troubles to be experienced.
- All defective products to be delivered by hand or through freight are to meet the necessary shipment requirements. (Anti-static protective, bubble wrap or box etc.)It is essential that legible barcode serial number belonging to the product be on the product. Otherwise, it is not covered in the scope of the guarantee.
- It is essential that products to be sent through freight definitely be together with delivery note, and that serial/model/malfunction details be written on delivery note to be sent (for example, breakdown report form), and that packaging content match with the products specified in the delivery note. Otherwise, freight is not accepted.
- The use of the Guarantee Certificate, submitted together with products with MAKELSAN trademark, is permitted by the T.R. Ministry of Industry and Commerce and General Directorate of Protection of Competition with no..... in accordance with the law, with no. 4077, and the notification, with no. TRKGM-95/116-117, issued basing the aforementioned law. MAKELSAN acknowledges and undertakes to obey the liabilities determined by the laws and legislations.

5.2 Cases Not Covered by the Guarantee

- Breakdowns resulting from the use of products contrary to the issues or the environment conditions (temperature, humidity etc.) specified in the user manual are not covered in the scope of guarantee.
- Damages and breakdowns resulting from the use of software, hardware, interface, accessories or consumables apart from those used together with products or recommended ones; changing place, wrong and insufficient maintenance, calibration or use; its operation contrary to environment specifications published for products; insufficiency of air installation; use of products in ambient having excessive humid or temperature; its operation in environment harmful for electrical circuits and abrasive;

and accidents, impacts, electric, shipment, natural disasters, not limited to the ones listed above, are not covered in the scope of product guarantee.

- In the general examination performed during the breakdown acceptance process, certain troubles causing products not to be covered in the scope of guarantee might not be understood. Provided that such faults come up in the detailed examination to be performed via technical service equipment, products are returned to customers.
- Products not covered in the scope of guarantee can, on demand of customer, be treated in a fee-paying way within the bounds of possibilities of the authorized service. Products out of the scope of guarantee, repairs of which are not possible are returned to customers.
- Damages and breakdowns resulting from treatments, internally or externally tampering, efforts to repair and spare part replacement of products, without approval of MAKELSAN, and those resulting from treatment of unauthorized service/dealer/person/establishment, are not covered in the scope of guarantee. Breakdown, cracks, scratches and wear, corrosion and dust to occur in time and by use in the outer surfaces of products (cabinet, cover, and front panel) are not covered in the scope of guarantee.
- In the event that original serial numbers, guarantee labels and stamps on products are removed or distorted, products are not covered in the scope of guarantee. No guarantee is issued against the use of products for any other purpose, apart from those specified in introduction or manual of products.
- Shelf lives of VRLA batteries are 6 months under the ambient temperature of 15 °C and 3 months under the ambient temperature of 25 °C.
- It is compulsory that systems to be purchased be commissioned within 3 months.

MAKELSAN®

Uninterruptible Power Supplies

CERTIFICATE OF GUARANTEE

MANUFACTURER COMPANY

Certificate Approval Date : --/--/----
Certificate No :

TITLE : **MAKELSAN MAKİNE KİMYA ELEKTRİK SAN. TİC. A.Ş.**
ADDRESS : **Deri Organize Sanayi Bölgesi 2.Yol I-5 Parsel P.K. 34957**
TELEPHONE : **0216 – 428 65 80**
FAX : **0216 – 327 51 64**

SIGNATURE AND STAMP OF COMPANY AUTHORITY

OF THE PRODUCT

TYPE : _____
TRADEMARK : _____
MODEL : _____
SERIAL NO / BANDEROLE : _____
DELIVERY DATE AND PLACE : _____
MAXIMUM REPAIR PERIOD : **20 business days**
GUARANTEE PERIOD : _____

VENDOR

TITLE : _____
ADDRESS : _____
TELEPHONE : _____
FAX : _____
INVOICE DATE / NO : _____
DATE / SIGNATURE AND STAMP : _____

CUSTOMER

TITLE / NAME : _____
ADDRESS : _____
SIGNATURE : _____

UPS AUTHORIZED SERVICES

Istanbul Deri Organize
Sanayi Bölgesi
2. Yol I-5 Parsel
34956 Tuzla/Istanbul
Tel: 0216 428 65 80
Fax: 0216 327 51 64
makelsan@makelsan.com.tr
www.makelsan.com.tr



CERTIFICATE OF GUARANTEE

- 1 – Guarantee period starts from the delivery date of the product and lasts.....years.
- 2 – The whole product, including all its parts are under the guarantee of our company.
- 3 – Provided that the product breaks down within the period of guarantee, the time passing during the repair process is added to the guarantee time. Repair time of the product is business days at most. This period starts from the date when the malfunction related to the product is informed to the service station, if there exists no service station, to one of seller, dealer, agency, representative, importer or one of manufacturer. Provided that the fault of industrial product cannot be removed within 10 business days, manufacturer or importer is obliged to assign another industrial product having similar features for the use of the consumer until the faulty product has been repaired.
- 4 – Provided that the product breaks down due to materials and workmanship or assembly faults within the period of guarantee, the product is repaired without claiming any charge for workmanship, any price for spare part replacement or any fee under any name.
- 5 – The product will be replaced without any charge in the events;
 - That passing over the product perpetuates due to the fact that the product repeats the same malfunction more than twice or different malfunctions occur more than four times in a year starting from the delivery date, on the condition of being in guarantee period;
 - That maximum time required for the repairment of the product is exceeded;
 - That, if there exists no service station, the repair of the malfunction is determined as impossible through a report to be issued one of seller, dealer, agency, representative, importer or manufacturer of the product respectively.
- 6 - Malfunctions resulting from the use of the product contrary to the issues specified in the user manual of the product are not covered in the scope of guarantee.
- 7 –For any trouble that may come up in terms of the Certificate of Guarantee, the Ministry of Industry and Commerce, General Directorate of Protection of Consumer and Competition can be applied.

NOTICE

- 8 – Under no circumstances shall the customer treat the product with the aim of repair, apart from MAKELSAN authorized service personnel.
- 9 – Damages and results originating from the violation of the 8th Article shall be invoiced to the customer.

The use of herein the certificate is permitted by the T.R. Ministry of Industry and Commerce and General Directorate of Protection of Consumers and Competition in accordance with the Law on the Protection of Consumers, with no. 4077, and the Notification Concerning the Application Principles of Guarantee Certificate, issued basing the aforementioned law.

6 CONTACT INFORMATION



www.makelsan.com.tr

Headquarter: İstanbul Deri Organize Sanayi Bölgesi 2. Yol I -5 Parsel 34956 Tuzla/ İstanbul

Tel : 0216 428 65 80

Fax : 0216 327 51 64

E-mail : makelsan@makelsan.com.tr

İzmir Office : Halkapınar Mah. 1348 Sok. 2AE Keremoğlu İş Merkezi Yenişehir – İzmir

Tel : 0232 469 47 00

Fax : 0232 449 47 00

E-mail : izmir@makelsan.com.tr

Ankara Office : Mustafa Kemal Mah. 2157 Sok. No:4/6 Çankaya-Ankara

Tel : 0312 219 82 35/37

Fax : 0312 219 82 36

E-mail : ankara@makelsan.com.tr

MAKELSAN®

Uninterruptible Power Supplies

www.makelsan.com.tr

Headquarter: İstanbul Deri Organize Sanayi Bölgesi 2. Yol I -5 Parsel 34956 Tuzla/ İstanbul

Tel : 0216 428 65 80

Fax : 0216 327 51 64

E-mail : makelsan@makelsan.com.tr

İzmir Office : Halkapınar Mah. 1348 Sok. 2AE Keremoğlu İş Merkezi Yenişehir – İzmir

Tel : 0232 469 47 00

Fax : 0232 449 47 00

E-mail : izmir@makelsan.com.tr

Ankara Office : Mustafa Kemal Mah. 2157 Sok. No:4/6 Çankaya-Ankara

Tel : 0312 219 82 35/37

Fax : 0312 219 82 36

E-mail : ankara@makelsan.com.tr